

GEAR MOTOR



免费咨询电话
400 928 8600



晟邦精密工业(苏州)有限公司
CHENG PANG PRECISION(SUZHOU) CO.,LTD

江苏省苏州市相城经济开发区漕湖产业园漕湖大道85号
NO.85 CAOHU ROAD, CAOHU INDUSTRIAL PARK,
XIANG CHENG ECONOMY ZONE, SUZHOU CITY,
JIANGSU PROVINCE, CHINA
TEL:+86-512-65751566 FAX:+86-512-65753566
E-mail:cbmotor@foxmail.com
<http://www.cbmotor.com.tw>

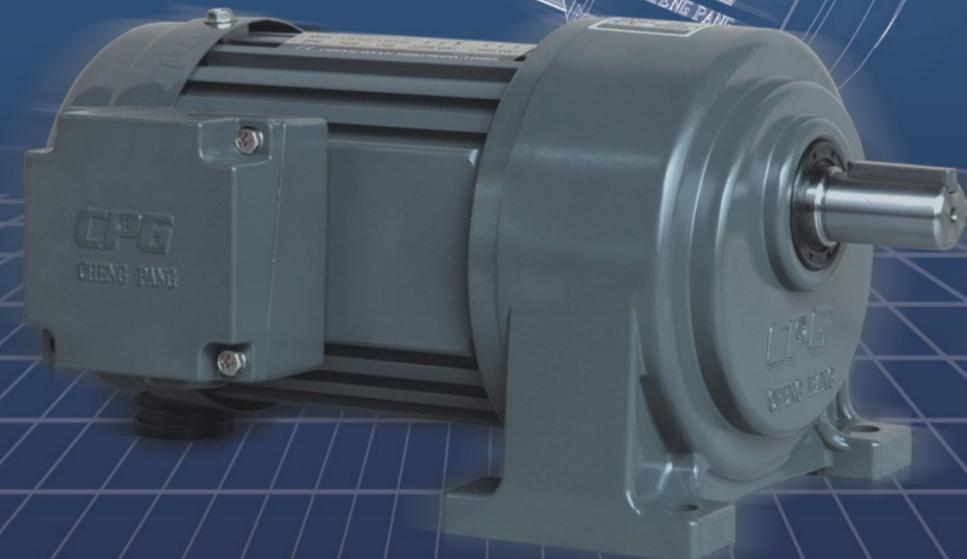

GEAR MOTOR

2019 版



Company Profile

公司簡介：

晟邦精密工業（蘇州）有限公司1990年創立於臺灣，於2002年在蘇州注冊成立（簡稱：晟邦精工，註冊商標：CPG）是一家集設計、加工、生產、銷售、維修服務於一體的齒輪減速機研發與生產的專業化優質企業。

晟邦精工創立以來，始終堅持“求實、開拓、勤業、高效”的經營理念，始終以質量第一，信譽第一來打造晟邦自己品牌。

主要產品：標準IEC三相鋁殼減速電機、臥式三相減速電機、高速比三相減速電機、三相縮框減速電機、入力法蘭齒輪減速機、入力法蘭高速比齒輪減速機、雙軸齒輪減速機、高速比雙軸齒輪減速機、單相半密鐵殼減速機等多種專業減速設備。



台灣廠房 TAIWAN FACTORY

Corporate culture

企業文化：

企業使命：專于一域，創百年基業。

企業願景：為全球合作伙伴提供更優質的產品與服務。

企業價值觀：“晟”信厚德，邦家立業，精益求精。

企業經營理念：求實、開拓、勤業、高效。



舊廠房 OLD FACTORY

Cheng Pang precision (Su Zhou) co., LTD., founded in 1990 in Taiwan, was registered in Su Zhou in 2002 (hereinafter referred to as Cheng Pang seiko, registered trademark: CPG), is a design, processing, production, sales, maintenance services in one of the gear reducer R & D and production of professional quality enterprises.

Since its establishment, Cheng Pang seiko has always adhered to the business philosophy of "truth-seeking, pioneering, diligent and efficient", and always put quality first and reputation first to build its own brand.

Main products: standard IEC three-phase aluminum shell reducer motor, horizontal three-phase gear motor, high speed than three-phase gear motor, gear motor three-phase reduction box, flange gear speed reducer, the flange into force into force than high speed gear speed reducer, biaxial gear reducer, high speed than the biaxial gear speed reducer, single phase half dense iron valley reducer, and other professional deceleration device.

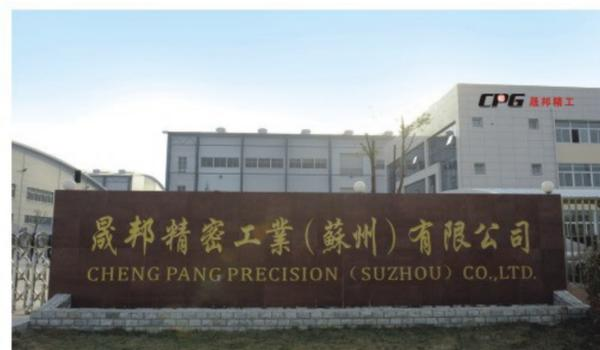

蘇州廠房 SUZHOU FACTORY

Development history

發展歷程：

- 1990年** 于臺灣創立城邦企業股份有限公司
Founded city-state enterprise co., LTD in Taiwan
- 1995年** 正式更名爲：城邦精密工業股份有限公司
Formally renamed: Cheng Pang precision co., LTD
- 1999年** 拓展中國大陸市場
Expand the mainland China market
- 2002年** 成立晟邦精密工業（蘇州）有限公司，註冊商標CPG
Cheng Pang precision industry (Su Zhou) co., LTD., registered trademark CPG
- 2004年** 通過ISO9001國際質量體系認證
Passed ISO9001 international quality system certification
- 2007年** 產品全系通過CE認證、國家CCC認證
Products through CE certification, national CCC certification
- 2008年** 獲得江蘇省質量誠信AAAA級品牌企業
Jiang Su province quality integrity AAAA - level brand enterprises
- 2014年** 通過安全生產標準化企業認證
Passed the safety production standardization enterprise certification
- 2015年** 獲得中國減速機行業重點推薦企業榮譽稱號
Won the honorary title of key recommended enterprises in China reducer industry
- 2016年** CPG獲得蘇州市知名商標、CPG牌齒輪減速機獲得蘇州市名牌產品
CPG was awarded Su Zhou famous brand, CPG brand gear reducer was awarded Su Zhou famous brand
- 2019年** 企業引進自動化生產綫，完成技術改造
The enterprise introduces the automatic production lines, completes the technical transformation



Certificates

榮譽認證

中國國家強制性產品認證證書 (Certificate for China compulsory product certification)



CCC 三相 (CCC 3-PHASE)



CCC 雙值電容
CCC Two-value capacitor



CCC 電容運轉
CCC Capacitor run

CE認證證書 (CE Marking)



CE三相

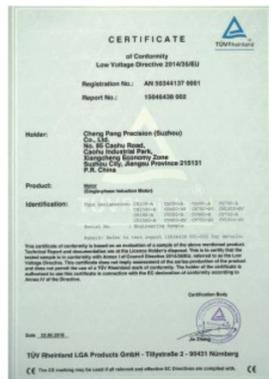

CE单相



单相电磁兼容



三相电磁兼容

ISO 9001國際品質系統認證標準 (ISO 9001 Quality system certificate)



ISO 9001:2008



ISO 9001:2008

Facilities

廠房設備

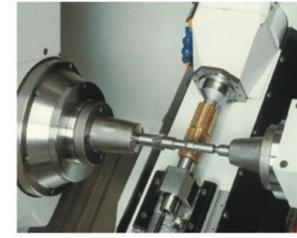

齒軸仿齒加工
PINION SKIVING

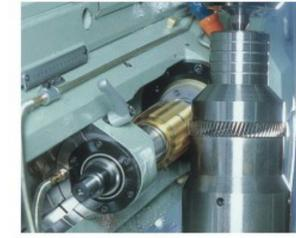

滾齒機
HOBBING MACHING



銑床及車床
MILLER & LATHE



齒輪檢驗機
GEAR TESTER



嚙合測試機
GEAR MESH TESTER



零件庫存
INVENTORY

Workshop assembly

現場裝機實配

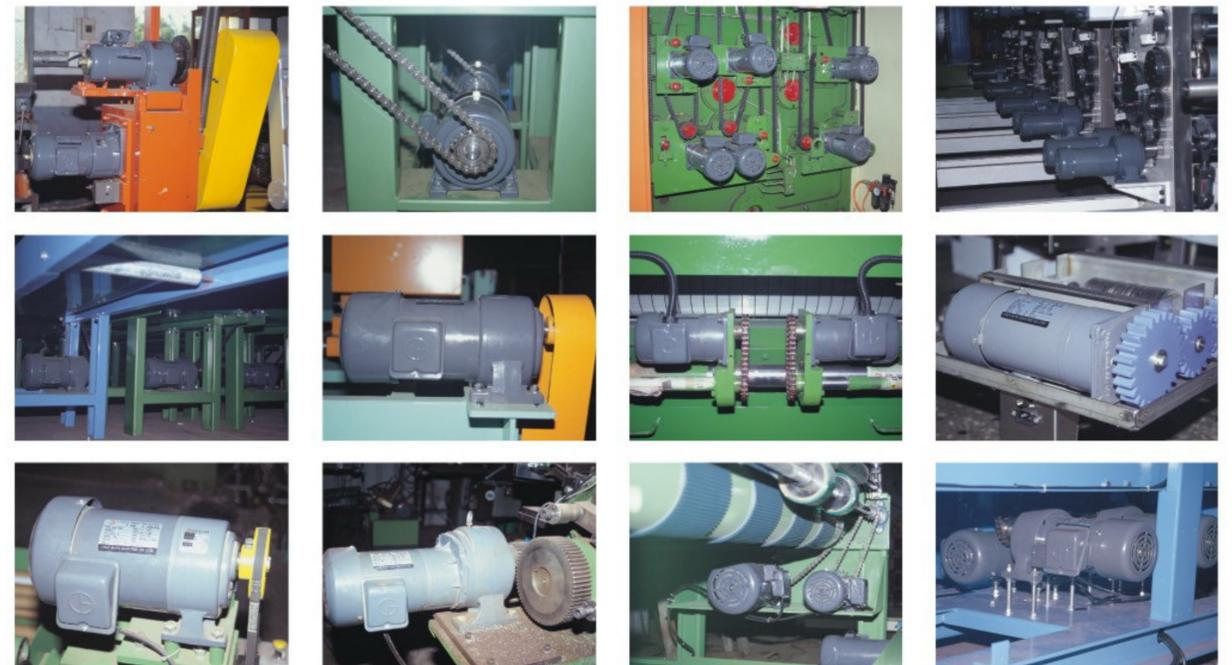

INDEX

目錄

No.1	型號說明 (DESCRIPTION OF MODEL)	07-08		
1-1	型號說明 (DESCRIPTION OF MODEL)			
1-2	配線盒方向選定 (TERMINAL BOX DIRECTION)			
1-3	入線口方向 (WIRE INLET DIRECTION)			
1-4	減速機與透氣塞安裝位置示意圖 (GEAR AND VENTILATION INSTALLATION)			
No.2	規格尺寸 (DIMENSIONS)	09-37		
2-1	附三相鋁/鐵殼(剎車)馬達減速機 WITH ALUMINUM / STEEL PALTE 3-PHASE(BRAKE) MOTOR.			
2-2	立式附三相(縮框)鋁殼(剎車)馬達減速機 --2#本體B型法蘭 VERTICAL (LIGHT DUTY) TYPE WITH ALUMINUM / STEEL PALTE 3-PHASE(BRAKE) MOTOR — 2# CODE B TYPE FLANGE			
2-3	高速比附三相鋁/鐵殼(剎車)馬達減速機 HIGH RATIO TYPE WITH ALUMINUM / STEEL PLATE 3-PHASE (BRAKE) MOTOR			
2-4	附三相縮框鋁/鐵殼(剎車)馬達減速機 LIGHT DUTY TYPE WITH ALUMINUM / STEEL PLATE 3-PHASE (BRAKE) MOTOR			
2-5	高速比附三相縮框鋁/鐵殼(剎車)馬達減速機 HIGH RATIO LIGHT DUTY TYPE WITH ALUMINUM / STEEL PLATE 3-PHASE (BRAKE) MOTOR			
2-6	入力法蘭齒輪減速機 FLANGE TYPE REDUCER WITHOT MOTOR			
2-7	入力法蘭高速比齒輪減速機 HIGH RATIO FLANGE TYPE REDUCER WITHOT MOTOR			
2-8	雙軸齒輪減速機 DOUBLE SHAFT TYPE REDUCER WITHOT MOTOR			
2-9	高速比雙軸齒輪減速機 DOUBLE SHAFT HIGH RATIO TYPE REDUCER WITHOT MOTOR			
2-10	附單相鋁殼/半密鐵殼(剎車)馬達減速機 WATTACHED TO THE SINGLE-PHASE ALUMINIUM SHELL/HALF CLOSE IRON SHELLS (BRAKE) MOTOR REDUCER			
2-11	附單相縮框鋁殼/半密鐵殼(剎車)馬達減速機 LWITH SINGLE BOX ALUMINUM SHELL/HALF CLOSE IRON SHELLS (BRAKE) MOTOR REDUCER			
2-12	附東元鐵殼(剎車)馬達減速機 WITH STEEL PLATE TECO (BRAKE) MOTOR .			
2-13	附三相鋁/鐵殼附DC24V送電剎車器 WITH ALUMINUM/STEEL PLATE 3-PHASE MOTOR W/DC24V POWER FOR BRAKE UNIT			
2-14-1	CV..S 立式標準IEC三相鋁殼(剎車)馬達 CV..S IEC VERTICAL 3-PHASE ALUMINUM (BRAKE) MOTOR			
2-14-2	CV..S 立式三相鋁殼(剎車)馬達——城邦規格 CV..S VERTICAL 3-PHASE ALUMINUM (BRAKE) MOTOR——CHENG PANG			
2-14-3	CV..S 立式三相鋁殼(剎車)馬達——B14 CV..S VERTICAL 3-PHASE ALUMINUM (BRAKE) MOTOR——B14			
2-15	CV..AT 立式單相鐵殼(剎車)馬達 CV..AT VERTICAL 1-PHASE STEEL PLATE (BRAKE) MOTOR			
2-16	W../CV..S 蝸輪減速機配立式齒輪減速機 W../CV..S WORM GEAR REDUCER COMBINE WITH VERTICAL GEARMOTOR			
No.3	零件剖面圖 (SECTIONAL DIAGRAM FOR PARTS)	38-40		
3-1	剎車零件分解圖 (SECTIONAL DIAGRAM FOR BRAKE UNIT)			
3-2	零件剖面圖 (SECTIONAL DIAGRAM FOR PARTS)			
3-3	減速機各部零件說明 (PARTS DETAILS)			
No.4	技術資料 (TECHNICAL TABLE)	41-56		
4-1	馬達規範 (MOTOR SPECIFICATION)			
4-1-1	標準馬達規範表 (STANDARD MOTOR SPECIFICATION)			
4-1-2	三相電壓全負載電流值 (3-PHASE/4 POLES FULL LOAD AMPERE)			
4-1-3	單相電壓全負載電流值 (1-PHASE/4 POLES FULL LOAD AMPERE)			
4-1-4	單相馬達電容器規格 (1-PHASE MOTOR CAPACITOR)			
4-2	輸出扭矩表 (OUTPUT TORQUE)			
4-3	出力軸懸垂荷重 (OVERHUNG LOAD)			
4-4	出力軸允許最大軸徑 (AVAILABLE MAX OUTPUT SHAFT DIAMETER)			
4-5	軸端攻牙 (OUTPUT SHAFT TAPPING)			
4-6	出力軸軸徑對照表 (OUTPUT SHAFT DIAMETER TABLE)			
4-7	公稱及實際速比 (NORMAL RATIO & ACTUAL RATIO)			
4-8	潤滑油 (LUBRICANT)			
4-9	速比/段數適用表 (RATIO / GEAR STAGE TABLE)			
4-10	接線方式 (WIRING DIAGRAM)			
4-11	剎車器性能說明 (FUNCTION FOR BRAKE UNIT)			
4-11-1	交流剎車器規格 (AC BRAKE UNIT SPECIFICATION)			
4-11-2	直流安全式剎車器規格 (DC BRAKE UNIT SPECIFICATION)			
4-12	標準東元/大同鑄鐵馬達 (IEC CAST IRON MOTOR)			
4-13	鍵/鍵槽加工尺寸 (KEY / KEYWAY DIMENSION)			
4-14	相關計算(CALCULATE DATA)			
No.5	故障排除 (TROUBLESHOOTING)	57		
No.6	各國電壓表 (COUNTRIES VOLTAGE)	58		

1-1 型號說明 (DESCRIPTION OF MODEL)



1-2 配線盒方向選定 (TERMINAL BOX DIRECTION)

TYPE	G1-左方向 LEFT SIDE	G2-右方向 RIGHT SIDE	G3-上方向 UPPER SIDE	G4-下方向 LOWER SIDE
CH 型 CH TYPE				
	G1	G2	G3	G4
CV 型 CV TYPE				
	G1	G2	G3	G4

1-3 入線口方向 (WIRE INLET DIRECTION)

G1		G2		G3		G4	
LD	LT	RD	RT	TL	TR	DL	DR
LF	LB	RF	RB	TF	TB	DF	DB

1-4 減速機與透氣塞安裝位置示意圖 (REDUCER AND VENTILATION INSTALLATION)

CH 機型 安裝 範 例			
	H0 標準 STANDARD (CPG 正立 CPG STAND)	H3 (左側 LEFT SIDE)	H6 (倒裝 INVERT)
	H9 (右側 RIGHT SIDE)	HU (軸向上 SHAFT UP)	HD (軸向下 SHAFT DOWN)
CV 機型 安裝 範 例			
	V0 標準 STANDARD (CPG 正立 CPG STAND)	V3 (CPG 順轉 90° CPG CLOCKWISE 90°)	V6 (CPG 順轉 180° CPG CLOCKWISE 180°)
	V9 (CPG 逆轉 90° CPG LEFT TURN 90°)	VU (軸向上 SHAFT UP)	VD (軸向下 SHAFT DOWN)

備註：1. 除標準安裝方式外，其餘安裝方式均需先告知本公司。
 NOTE: 1. IN ADDITION TO THE STANDARD INSTALLATION, THE OTHER INSTALLATION IS REQUIRED PRIOR NOTICE OF THE COMPANY.

2-1 附三相鋁/鐵殼(剎車)馬達減速機

WITH ALUMINUM / STEEL PALTE 3-PHASE(BRAKE) MOTOR.



CH..S 臥式
CH..S HORIZONTAL TYPE



CV..S 立式
CV..S VERTICAL TYPE

臥式附三相 HORIZONTAL TYPE

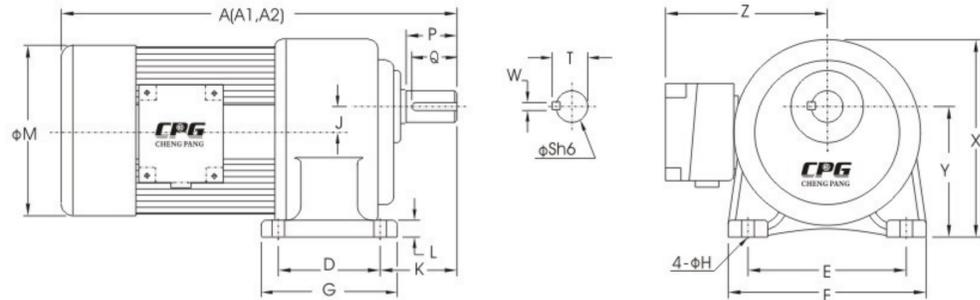

立式附三相 VERTICAL TYPE

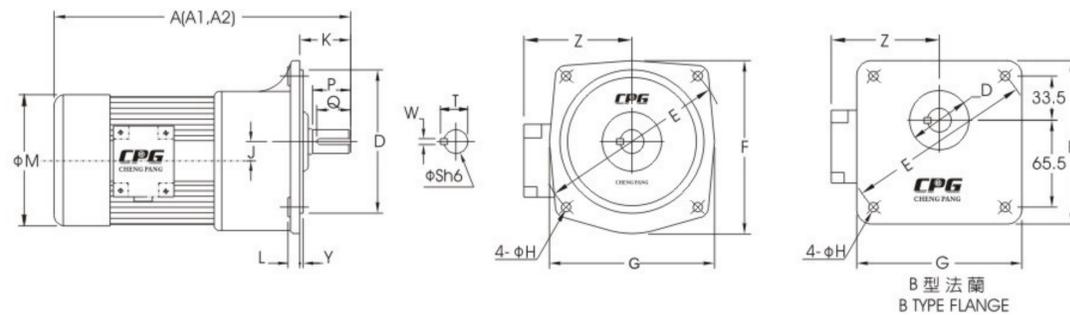

出力軸尺寸 OUTPUT SHAFT

型番 SIZE(S)	出力軸 SHAFT			鍵槽 KEYWAY			鍵 KEY
	Sh6	P	W	T	Q		SPEC'
18	φ 18	30	5	20.2	27		5 * 5 * 27
22	φ 22	40	7	25	35		7 * 7 * 35
28	φ 28	45	7	31.1	40		7 * 7 * 40
32	φ 32	55	10	35.5	50		10 * 8 * 50
40	φ 40	65	10	43.5	60		10 * 8 * 60
50	φ 50	80	14	54	75		14 * 9 * 75

適用機型 APPLICABLE MODELS : CH..S, CH..ST, CH..SB, CH..STB, CV..S, CV..ST, CV..SB, CV..STB

臥式 HORIZONTAL TYPE (Dimension in mm)

馬力 KW	減速比 RATIO	本體 CODE	型番 SIZE(S)	A	A1	A2	D	E	F	G	H	J	K	L	M	X	Y	Z
100W 1/8 HP	3-50	1 #	18	250	250	250	40	110	135	65	9	16	50	10	133	138	88.5	120
	60-200	2 #	22	280	280	280	65	130	158	90	11	17.5	60	13	133	152	97.5	120
	3-10	1 #	18	285	285	285	40	110	135	65	9	16	50	10	133	138	88.5	120
200W 1/4 HP	15-90	2 #	22	315	315	315	65	130	158	90	11	17.5	60	13	133	152	97.5	120
	100-200	3 #	28	350	350	350	90	140	178	120	12	23	68	17	133	178	116	120
	3-10	1 #	18	285	285	285	40	110	135	65	9	16	50	10	133	138	88.5	120
300W	15-90	2 #	22	315	315	315	65	130	158	90	11	17.5	60	13	133	152	97.5	120
	100-200	3 #	28	350	350	350	90	140	178	120	12	23	68	17	133	178	116	120
	3-10	2 #	22	330	330	330	65	130	158	90	11	17.5	60	13	167	152	97.5	135
400W 1/2 HP	15-90	3 #	28	360	360	360	90	140	178	120	12	23	68	17	167	178	116	135
	100-200	4 #	32	395	395	395	130	170	210	165	13	30	70	23	167	212	140	135
	3-10	2 #	22	330	330	330	65	130	158	90	11	17.5	60	13	167	152	97.5	135
550W 3/4 HP	15-90	3 #	28	360	360	360	90	140	178	120	12	23	68	17	167	178	116	135
	100-200	4 #	32	395	395	395	130	170	210	165	13	30	70	23	167	212	140	135
	3-25	3 #	28	380	380	380	90	140	178	120	12	23	68	17	167	178	116	135
750W 1 HP	30-120	4 #	32	410	410	410	130	170	210	165	13	30	70	23	167	212	140	135
	125-200	5 #	40	465	465	465	150	210	265	198	15	36	89	24	167	250	162	135
	3-25	3 #	28	400	400	400	90	140	178	120	12	23	68	17	167	178	116	135
900W	30-120	4 #	32	430	430	430	130	170	210	165	13	30	70	23	167	212	140	135
	125-200	5 #	40	485	485	485	150	210	265	198	15	36	89	24	167	250	162	135
	3-25	3 #	28	400	400	400	90	140	178	120	12	23	68	17	167	178	116	135
1100W 1.5HP	30-120	4 #	32	430	430	430	130	170	210	165	13	30	70	23	167	212	140	135
	125-200	5 #	40	485	485	485	150	210	265	198	15	36	89	24	167	250	162	135
	3-30	4 #	32	450	450	450	130	170	210	165	13	30	70	23	192	212	140	146
1100W 1.5HP	40-100	5 #	40	510	510	510	150	210	265	198	15	36	89	24	192	250	162	146
	110-180	6 #	50	560	560	560	170	265	325	238	18	51	120	31.5	192	308	200	146
	3-30	4 #	32	450	450	450	130	170	210	165	13	30	70	23	192	212	140	146
1500W 2 HP	40-100	5 #	40	510	510	510	150	210	265	198	15	36	89	24	192	250	162	146
	110-180	6 #	50	560	560	560	170	265	325	238	18	51	120	31.5	192	308	200	146
	3-40	5 #	40	530	530	530	150	210	265	198	15	36	89	24	212	250	162	160
2200W 3 HP	45-100	6 #	50	590	590	590	170	265	325	238	18	51	120	31.5	212	308	200	160
	110-180	6 #	50	560	560	560	170	265	325	238	18	51	120	31.5	212	308	200	160
	3-10	5 #	40	570	570	570	150	210	265	198	15	36	89	24	212	250	162	160
3700W 5 HP	15-100	6 #	50	630	630	630	170	265	325	238	18	51	120	31.5	212	308	200	160
	15-100	6 #	50	630	630	630	170	265	325	238	18	51	120	31.5	212	308	200	160
	3-10	5 #	40	570	570	570	150	210	265	198	15	36	89	24	212	250	162	160

* : 減速機高度152,風罩到腳座底部高度為163.

立式 VERTICAL TYPE (Dimension in mm)

馬力 KW	減速比 RATIO	本體 CODE	型番 SIZE(S)	A	A1	A2	D	E	F	G	H	J	K	L	M	Y	Z
100W 1/8 HP	3-50	1 #	*18	250	250	250	50	140	120	120	9	16	38.5	12	133	6	120
	60-200	2 #	22	280	280	280	148	185	175	165	11	17.5	48	12	133	3	120
	3-10	1 #	*18	285	285	285	50	140	120	120	9	16	38.5	12	133	6	120
200W 1/4 HP	15-90	2 #	22	315	315	315	148	185	175	165	11	17.5	48	12	133	3	120
	100-200	3 #	28	350	350	350	170	220	205	195	12	23	58	13	133	3	120
	3-10	1 #	*18	285	285	285	50	140	120	120	9	16	38.5	12	133	6	120
300W	15-90	2 #	22	315	315	315	148	185	175	165	11	17.5	48	12	133	3	120
	100-200	3 #	28	350	350	350	170	220	205	195	12	23	58	13	133	3	120
	3-10	2 #	22	330	330	330	148	185	175	165	11	17.5	48	12	167	3	135
400W 1/2 HP	15-90	3 #	28	360	360	360	170	220	205	195	12	23	58	13	167	3	135
	100-200	4 #	32	395	395	395	185	255	248	225	15	30	65	16	167	3	135
	3-10	2 #	22	330	330	330	148	185	175	165	11	17.5	48	12	167	3	135
550W 3/4 HP	15-90	3 #	28	360	360	360	170	220	205	195	12	23	58	13	167	3	135
	100-200	4 #	32	395	395	395	185	255	248	225	15	30	65	16	167	3	135
	3-25	3 #	28	380	380	380	170	220	205	195	12	23	58	13	167	3	135
750W 1 HP	30-120	4 #	32	410	410	410	185	255	248	225	15	30	65	16	167	3	135
	125-200	5 #	40	465	465	465	230	310	291	272	15	36	85	21	167	5	135
	3-25	3 #	28	400	400	400	170	220	205	195	12	23	58	13	167	3	135
900W	30-120	4 #	32	430	430	430	185	255	248	225	15	30	65	16	167	3	135
	125-200	5 #	40	485	485	485	230	310	291	272	15	36	85	21	167	5	135
	3-25	3 #	28	400	400	400	170	220	205	195	12	23	58	13	167	3	135
1100W 1.5HP	30-120	4 #	32	430	430	430	185	255	248	225	15	30	65	16	167	3	135
	125-200	5 #	40	485	485	485	230	310	291	272	15	36	85	21	167	5	135
	3-30	4 #	32	450	450	450	185	255	248	225	15	30	65	16	192	3	146
1100W 1.5HP	40-100	5 #	40	510	510	510	230	310	291	272	15	36	85	21	192	5	146
	110-180	6 #	50	560	560	560	280	390	372	342	18	51	92	25	192	5	146
	3-30	4 #	32	45													

2-2 立式附三相(縮框)鋁殼(剎車)馬達減速機——2#本體B型法蘭
VERTICAL (LIGHT DUTY) TYPE WITH ALUMINUM /
STEEL PALTE 3-PHASE(BRAKE) MOTOR—— 2# CODE B TYPE FLANGE



CV..S (CV..SB) 附三相鋁殼
CV..S (CV..SB) VERTICAL TYPE

CV..SZ (CV..SZB) 附三相縮框鋁殼
CV..SZ (CV..SZB) VERTICAL LIGHT DUTY TYPE

附三相鋁殼 VERTICAL TYPE

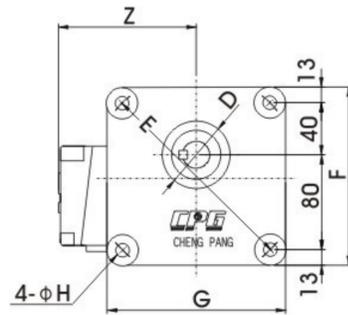
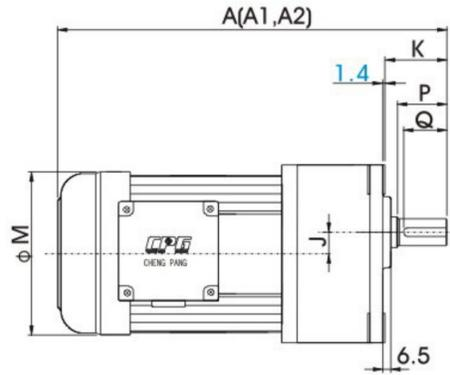

附三相縮框鋁殼 VERTICAL LIGHT DUTY TYPE

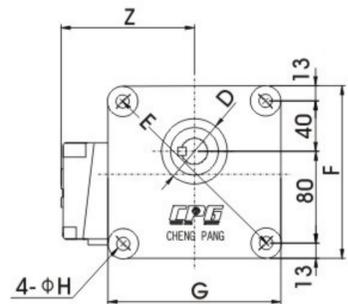
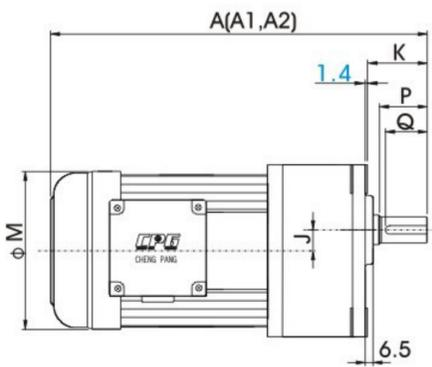

出力軸尺寸 OUTPUT SHAFT

型番 SIZE(S)	出力軸 SHAFT		鍵槽 KEYWAY			鍵 KEY
	Sh6	P	W	T	Q	SPEC'
22	φ22	40	7	25	35	7 * 7 * 35

適用機型 APPLICABLE MODELS : CV..S, CV..ST, CV..SB, CV..STB, CV..SZ, CV..STZ, CV..SZB, CV..STZB

附三相鋁殼 VERTICAL TYPE (Dimension in mm)

馬力 KW	減速比 RATIO	本體 CODE	型番 SIZE(S)	A	A1	A2	D	E	F	G	H	J	K	M	Z
100W 1/8 HP	60-200	2#	*22	280	280	280	55	170	146	146	11	19.662	48.6	133	120
200W 1/4 HP	15-90	2#	*22	315	315	315	55	170	146	146	11	19.662	48.6	133	120
300W	15-90	2#	*22	315	315	315	55	170	146	146	11	19.662	48.6	133	120
400W 1/2 HP	3-10	2#	*22	330	330	330	55	170	146	146	11	19.662	48.6	167	135
550W 3/4HP	3-10	2#	*22	330	330	330	55	170	146	146	11	19.662	48.6	167	135

附三相縮框鋁殼 VERTICAL LIGHT DUTY TYPE (Dimension in mm)

馬力 KW	減速比 RATIO	本體 CODE	型番 SIZE(S)	A	A1	A2	D	E	F	G	H	J	K	M	Z
200W 1/4 HP	100-200	2#	*22	315	315	315	55	170	146	146	11	19.662	48.6	133	120
300W	100-200	2#	*22	315	315	315	55	170	146	146	11	19.662	48.6	133	120
400W 1/2 HP	15-90	2#	*22	330	330	330	55	170	146	146	11	19.662	48.6	167	135
550W 3/4HP	15-90	2#	*22	330	330	330	55	170	146	146	11	19.662	48.6	167	135
750W 1 HP	3-25	2#	*22	330	330	330	55	170	146	146	11	19.662	48.6	167	135

備註：A：三相鋁殼馬達，WITH 3-PHASE ALUMINUM MOTOR。 A1：三相鐵殼馬達，WITH 3-PHASE STEEL PLATE MOTOR。

A2：三相馬達附剎車器，WITH 3-PHASE BRAKE MOTOR。 *：屬於B型出力法蘭，BELONG TO B TYPE OUTPUT FLANGE。

此本體同樣適用機型 APPLICABLE MODELS：CVM 立式入力法蘭齒輪減速機 CVM FLANGE TYPE WITH VERTICAL MOTOR

CVD 立式雙軸齒輪減速機 CVD DOUBLE SHAFT TYPE WITH VERTICAL MOTOR

【窮之本】

多因放蕩不經營 逐漸窮
不惜錢財手頭鬆 容易窮
朝朝睡到日頭紅 邈邈窮
家有田地不務農 懶惰窮
結識富豪為親朋 攀尚窮
好打官司逞英雄 鬥氣窮
借債納利裝門風 自弄窮
妻孥饑懶子飄蓬 命當窮
子孫相交不良朋 局騙窮
好賭貪花戀酒國 徹底窮

【富之由】

不辭辛苦走道路 勤儉富
買賣公平多主顧 忠厚富
聽得雞鳴離床鋪 留心富
手足不停理家務 終久富
常防火盜管門戶 謹慎富
不去為非犯法度 守分富
合家大小相幫忙 同心富
妻兒賢慧無欺妒 幫家富
教子訓孫立門戶 後代富
存心積德天佑護 為善富

逃避不一定能夠躲的過，
面對不一定就會最難過，
得到不一定就會最滿足，
失去不一定就是最損失，
轉身不一定就是最軟弱，
挺身不一定就是最堅強。

2-3 高速比附三相鋁 / 鐵殼(剎車)馬達減速機
HIGH RATIO TYPE WITH ALUMINUM / STEEL PLATE 3-PHASE (BRAKE) MOTOR



CH..S 臥式
CH..S HORIZONTAL HIGH RATIO TYPE



CV..S 立式
CV..S VERTICAL HIGH RATIO TYPE

臥式高速比 HORIZONTAL HIGH RATIO TYPE

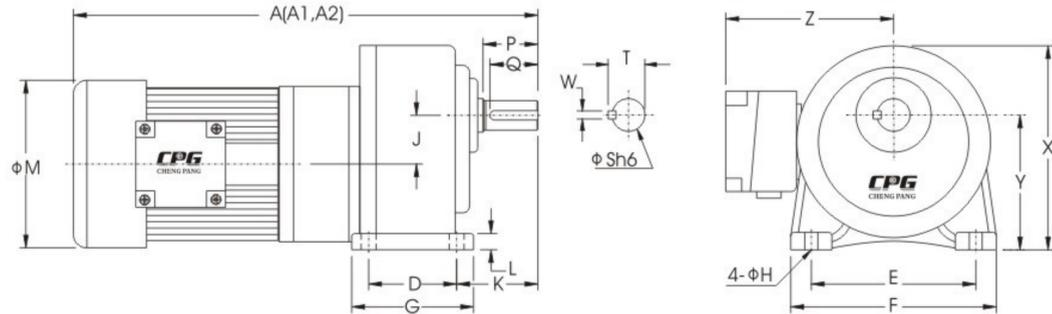

立式高速比 VERTICAL HIGH RATIO TYPE

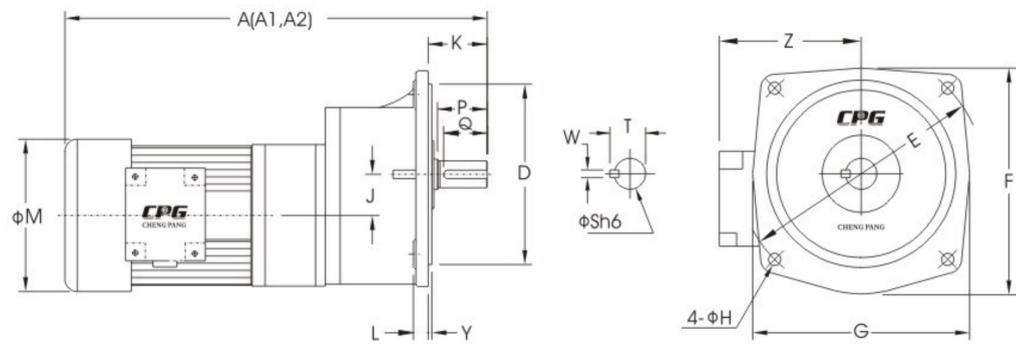

出力軸尺寸 OUTPUT SHAFT

型番 SIZE(S)	出力軸 SHAFT		鍵槽 KEYWAY			鍵 KEY
	Sh6	P	W	T	Q	SPEC'
28	Φ28	45	7	31.1	40	7 * 7 * 40
32	Φ32	55	10	35.5	50	10 * 8 * 50
40	Φ40	65	10	43.5	60	10 * 8 * 60
50	Φ50	80	14	54	75	14 * 9 * 75

適用機型 APPLICABLE MODELS : CH..S, CH..ST, CH..SB, CH..STB, CV..S, CV..ST, CV..SB, CV..STB,

臥式高速比 HORIZONTAL HIGH RATIO TYPE (Dimension in mm)

馬力 KW	減速比 RATIO	本體 CODE	型番 SIZE(S)	A	A1	A2	D	E	F	G	H	J	K	L	M	X	Y	Z
100W 1/8 HP	250-1800	1#+3#	28	375	375	375	90	140	178	120	12	39	68	17	133	178	116	120
200W 1/4 HP	250-1800	2#+4#	32	460	460	460	130	170	210	165	13	47.5	70	23	133	212	140	120
300W	250-1800	2#+4#	32	460	460	460	130	170	210	165	13	47.5	70	23	133	212	140	120
400W 1/2 HP	250-1800	3#+5#	40	550	550	550	150	210	265	198	15	59	89	24	167	250	162	135
550W 3/4HP	250-1800	3#+5#	40	550	550	550	150	210	265	198	15	59	89	24	167	250	162	135
750W 1 HP	250-1800	3#+6#	50	620	620	620	170	265	325	238	18	74	120	31.5	167	308	200	135
900W	250-1800	3#+6#	50	640	640	640	170	265	325	238	18	74	120	31.5	167	308	200	135
1100W 1.5HP	250-1800	3#+6#	50	640	640	640	170	265	325	238	18	74	120	31.5	167	308	200	135
1100W 1.5HP	250-1800	4#+6#	50	690	690	690	170	265	325	238	18	81	120	31.5	192	308	200	146
1500W 2HP	250-1800	4#+6#	50	690	690	690	170	265	325	238	18	81	120	31.5	192	308	200	146

立式高速比 VERTICAL HIGH RATIO TYPE (Dimension in mm)

馬力 KW	減速比 RATIO	本體 CODE	型番 SIZE(S)	A	A1	A2	D	E	F	G	H	J	K	L	M	Y	Z
100W 1/8 HP	250-1800	1#+3#	28	375	375	375	170	220	205	195	12	39	58	13	133	3	120
200W 1/4 HP	250-1800	2#+4#	32	460	460	460	185	255	248	225	15	47.5	65	16	133	3	120
300W	250-1800	2#+4#	32	460	460	460	185	255	248	225	15	47.5	65	16	133	3	120
400W 1/2 HP	250-1800	3#+5#	40	550	550	550	230	310	291	272	15	59	85	21	167	5	135
550W 3/4HP	250-1800	3#+5#	40	550	550	550	230	310	291	272	15	59	85	21	167	5	135
750W 1 HP	250-1800	3#+6#	50	620	620	620	280	390	372	342	18	74	92	25	167	5	135
900W	250-1800	3#+6#	50	640	640	640	280	390	372	342	18	74	92	25	167	5	135
1100W 1.5HP	250-1800	3#+6#	50	640	640	640	280	390	372	342	18	74	92	25	167	5	135
1100W 1.5HP	250-1800	4#+6#	50	690	690	690	280	390	372	342	18	81	92	25	192	5	146
1500W 2HP	250-1800	4#+6#	50	690	690	690	280	390	372	342	18	81	92	25	192	5	146

備註 : A : 三相鋁殼馬達 . WITH 3-PHASE ALUMINUM MOTOR.
A1 : 三相鐵殼馬達 . WITH 3-PHASE STEEL PLATE MOTOR.
A2 : 三相馬達附剎車器 . WITH 3-PHASE BRAKE MOTOR .



2-4 附三相縮框鋁 / 鐵殼(剎車)馬達減速機
LIGHT DUTY TYPE WITH ALUMINUM / STEEL PLATE 3-PHASE (BRAKE) MOTOR



CH..SZ 臥式附三相縮框
CH..SZ HORIZONTAL LIGHT DUTY TYPE

CV..SZ 立式附三相縮框
CV..SZ VERTICAL LIGHT DUTY TYPE

臥式附三相縮框 HORIZONTAL LIGHT DUTY TYPE

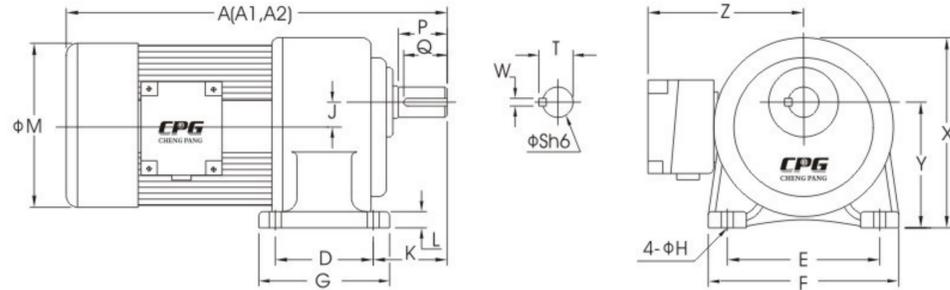

立式附三相縮框 VERTICAL LIGHT DUTY TYPE

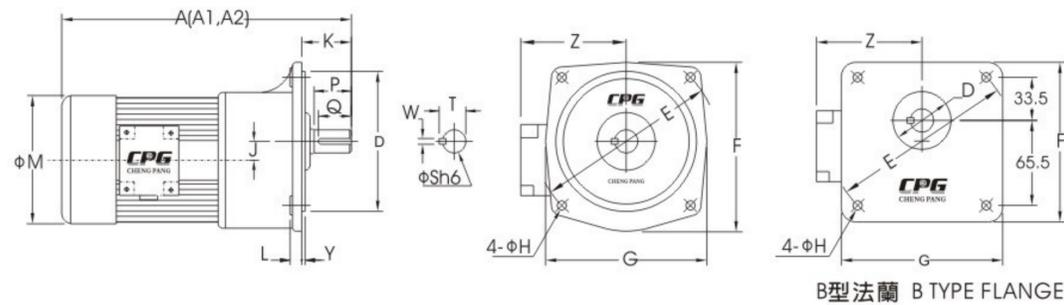

出力軸尺寸 OUTPUT SHAFT

型番 SIZE(S)	出力軸 SHAFT		鍵槽 KEYWAY			鍵 KEY
	Sh6	P	W	T	Q	SPEC'
18	φ18	30	5	20.2	27	5*5*27
22	φ22	40	7	25	35	7*7*35
28	φ28	45	7	31.1	40	7*7*40
32	φ32	55	10	35.5	50	10*8*50
40	φ40	65	10	43.5	60	10*8*60

適用機型 APPLICABLE MODELS : CH..SZ, CH..STZ, CH..SZB, CH..STZB, CV..SZ, CV..STZ, CV..SZB, CV..STZB

臥式附三相縮框 HORIZONTAL LIGHT DUTY TYPE (Dimension in mm)

馬力 KW	減速比 RATIO	本體 CODE	型番 SIZE(S)	A	A1	A2	D	E	F	G	H	J	K	L	M	X	Y	Z
100W 1/8HP	60-200	1#	18	260	260	260	40	110	135	65	9	16	50	10	133	138	88.5	120
200W 1/4HP	15-90	1#	18	295	295	295	40	110	135	65	9	16	50	10	133	138	88.5	120
	100-200	2#	22	315	315	315	65	130	158	90	11	17.5	60	13	133	152	97.5	120
300W	15-90	1#	18	295	295	295	40	110	135	65	9	16	50	10	133	138	88.5	120
	100-200	2#	22	315	315	315	65	130	158	90	11	17.5	60	13	133	152	97.5	120
400W 1/2HP	15-90	2#	22	330	330	330	65	130	158	90	11	17.5	60	13	167	*152	97.5	135
	100-200	3#	28	360	360	360	90	140	178	120	12	23	68	17	167	178	116	135
550W 3/4HP	15-90	2#	22	330	330	330	65	130	158	90	11	17.5	60	13	167	*152	97.5	135
	100-200	3#	28	360	360	360	90	140	178	120	12	23	68	17	167	178	116	135
750W 1HP	3-25	2#	22	330	330	330	65	130	158	90	11	17.5	60	13	167	152	97.5	135
	30-120	3#	28	380	380	380	90	140	178	120	12	23	68	17	167	178	116	135
900W	125-200	4#	32	410	410	410	130	170	210	165	13	30	70	23	167	212	140	135
	3-25	2#	22	350	350	350	65	130	158	90	11	17.5	60	13	167	152	97.5	135
1100W 1.5HP	30-120	3#	28	400	400	400	90	140	178	120	12	23	68	17	167	178	116	135
	125-200	4#	32	430	430	430	130	170	210	165	13	30	70	23	167	212	140	135
1100W 1.5HP	3-30	3#	28	420	420	420	90	140	178	120	12	23	68	17	192	178	116	146
	40-100	4#	32	450	450	450	130	170	210	165	13	30	70	23	192	212	140	146
1500W 2HP	110-150	5#	40	510	510	510	150	210	265	198	15	36	89	24	192	250	162	146
	3-30	3#	28	420	420	420	90	140	178	120	12	23	68	17	192	178	116	146
2200W 3HP	40-100	4#	32	450	450	450	130	170	210	165	13	30	70	23	192	212	140	146
	110-150	5#	40	510	510	510	150	210	265	198	15	36	89	24	192	250	162	146
3700W 5HP	15-80	5#	40	570	570	570	150	210	265	198	15	36	89	24	212	250	162	160

* : 減速機高度152,風罩到腳座底部高度為163.

立式附三相縮框 VERTICAL LIGHT DUTY TYPE (Dimension in mm)

馬力 KW	減速比 RATIO	本體 CODE	型番 SIZE(S)	A	A1	A2	D	E	F	G	H	J	K	L	M	Y	Z
100W 1/8HP	60-200	1#	*18	260	260	260	50	140	120	120	9	16	38.5	12	133	6	120
200W 1/4HP	15-90	1#	*18	295	295	295	50	140	120	120	9	16	38.5	12	133	6	120
	100-200	2#	22	315	315	315	148	185	175	165	11	17.5	48	12	133	3	120
300W	15-90	1#	*18	295	295	295	50	140	120	120	9	16	38.5	12	133	6	120
	100-200	2#	22	315	315	315	148	185	175	165	11	17.5	48	12	133	3	120
400W 1/2HP	15-90	2#	22	330	330	330	148	185	175	165	11	17.5	48	12	167	3	135
	100-200	3#	28	360	360	360	170	220	205	195	12	23	58	13	167	3	135
550W 3/4HP	15-90	2#	22	330	330	330	148	185	175	165	11	17.5	48	12	167	3	135
	100-200	3#	28	360	360	360	170	220	205	195	12	23	58	13	167	3	135
750W 1HP	3-25	2#	22	330	330	330	148	185	175	165	11	17.5	48	12	167	3	135
	30-120	3#	28	380	380	380	170	220	205	195	12	23	58	13	167	3	135
900W	125-200	4#	32	410	410	410	185	255	248	225	15	30	65	16	167	3	135
	3-25	2#	22	350	350	350	148	185	175	165	11	17.5	48	12	167	3	135
1100W 1.5HP	30-120	3#	28	400	400	400	170	220	205	195	12	23	58	13	167	3	135
	125-200	4#	32	430	430	430	185	255	248	225	15	30	65	16	167	3	135
1100W 1.5HP	3-30	3#	28	420	420	420	170	220	205	195	12	23	58	13	192	3	146
	40-100	4#	32	450	450	450	185	255	248	225	15	30	65	16	192	3	146
1500W 2HP	110-150	5#	40	510	510	510	230	310	291	272	15	36	85	21	192	5	146
	3-30	3#	28	420	420	420	170	220	205	195	12	23	58	13	192	3	146
2200W 3HP	40-100	4#	32	450	450	450	185	255	248	225	15	30	65	16	192	3	146
	110-150	5#	40	510	510	510	230	310	291	272	15	36	85	21	192	5	146
3700W 5HP	15-80	5#	40	570	570	570	230	310	291	272	15	36	85	21	212	5	160

備註 : A : 三相鋁殼馬達. WITH 3-PHASE ALUMINUM MOTOR.
A1 : 三相鐵殼馬達. WITH 3-PHASE STEEL PLATE MOTOR.
A2 : 三相馬達附剎車器. WITH 3-PHASE BRAKE MOTIOR.
* : 屬於B型出力法蘭. BELONG TO B TYPE OUTPUT FLANGE.

2-5 高速比附三相縮框鋁 / 鐵殼(剎車)減速機
HIGH RATIO LIGHT DUTY TYPE WITH ALUMINUM / STEEL PLATE 3-PHASE (BRAKE) MOTOR



CH..SZ 臥式高速比附三相縮框
CH..SZ HORIZONTAL HIGH RATIO TYPE

CV..SZ 立式高速比附三相縮框
CV..SZ VERTICAL HIGH RATIO TYPE

臥式高速比附三相縮框 HORIZONTAL HIGH RATIO TYPE

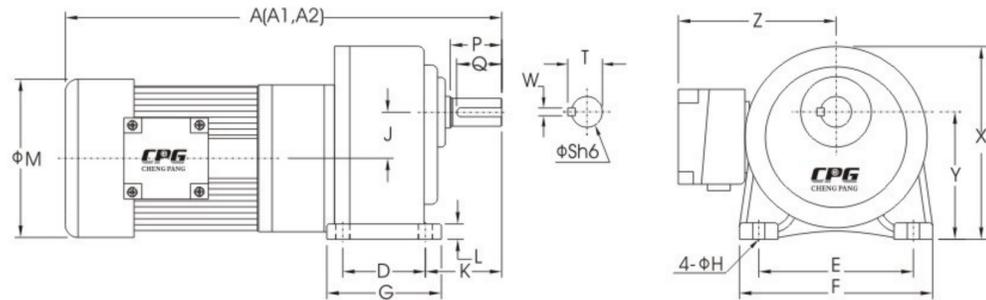

立式高速比附三相縮框 VERTICAL HIGH RATIO TYPE

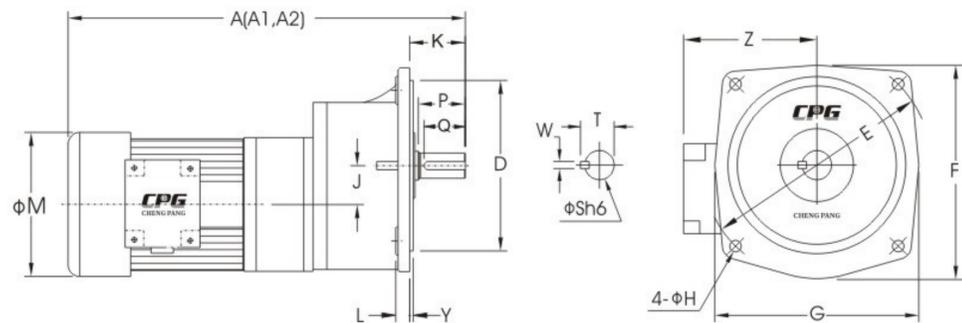

出力軸尺寸 OUTPUT SHAFT

型番 SIZE(S)	出力軸 SHAFT		鍵槽 KEYWAY			鍵 KEY
	Sh6	P	W	T	Q	SPEC'
22	φ22	40	7	25	35	7*7*35
28	φ28	45	7	31.1	40	7*7*40
32	φ32	55	10	35.5	50	10*8*50
40	φ40	65	10	43.5	60	10*8*60

適用機型 APPLICABLE MODELS : CH..SZ,CH..STZ,CH..SZB,CH..STZB,CV..SZ,CV..STZ,CV..SZB,CV..STZB

臥式高速比附三相縮框 HORIZONTAL HIGH RATIO TYPE (Dimension in mm)

馬力 KW	減速比 RATIO	本體 CODE	型番 SIZE(S)	A	A1	A2	D	E	F	G	H	J	K	L	M	X	Y	Z
100W 1/8HP	250-1800	1#+2#	22	345	345	345	65	130	158	90	11	33.5	60	13	133	152	97.5	120
200W 1/4HP	250-1800	1#+3#	28	410	410	410	90	140	178	120	12	39	68	17	133	178	116	120
300W	250-1800	1#+3#	28	410	410	410	90	140	178	120	12	39	68	17	133	178	116	120
400W 1/2HP	250-1800	2#+4#	32	480	480	480	130	170	210	165	13	47.5	70	23	167	212	140	135
550W 3/4HP	250-1800	2#+4#	32	480	480	480	130	170	210	165	13	47.5	70	23	167	212	140	135
750W 1HP	250-1800	3#+5#	40	570	570	570	150	210	265	198	15	59	89	24	167	250	162	135
900W	250-1800	3#+5#	40	590	590	590	150	210	265	198	15	59	89	24	167	250	162	135
1100W 1.5HP	250-1800	3#+5#	40	590	590	590	150	210	265	198	15	59	89	24	167	250	162	135
1100W 1.5HP	250-1800	3#+5#	40	620	620	620	150	210	265	198	15	59	89	24	192	250	162	146
1500W 2HP	250-1800	3#+5#	40	620	620	620	150	210	265	198	15	59	89	24	192	250	162	146

立式高速比附三相縮框 VERTICAL HIGH RATIO TYPE (Dimension in mm)

馬力 KW	減速比 RATIO	本體 CODE	型番 SIZE(S)	A	A1	A2	D	E	F	G	H	J	K	L	M	Y	Z
100W 1/8HP	250-1800	1#+2#	22	345	345	345	148	185	175	165	11	33.5	48	12	133	3	120
200W 1/4HP	250-1800	1#+3#	28	410	410	410	170	220	205	195	12	39	58	13	133	3	120
300W	250-1800	1#+3#	28	410	410	410	170	220	205	195	12	39	58	13	133	3	120
400W 1/2HP	250-1800	2#+4#	32	480	480	480	185	255	248	225	15	47.5	65	16	167	3	135
550W 3/4HP	250-1800	2#+4#	32	480	480	480	185	255	248	225	15	47.5	65	16	167	3	135
750W 1HP	250-1800	3#+5#	40	570	570	570	230	310	291	272	15	59	85	21	167	5	135
900W	250-1800	3#+5#	40	590	590	590	230	310	291	272	15	59	85	21	167	5	135
1100W 1.5HP	250-1800	3#+5#	40	590	590	590	230	310	291	272	15	59	85	21	167	5	135
1100W 1.5HP	250-1800	3#+5#	40	620	620	620	230	310	291	272	15	59	85	21	192	5	146
1500W 2HP	250-1800	3#+5#	40	620	620	620	230	310	291	272	15	59	85	21	192	5	146

備註 : A : 三相鋁殼馬達. WITH 3-PHASE ALUMINUM MOTOR.
A1 : 三相鐵殼馬達. WITH 3-PHASE STEEL PLATE MOTOR.
A2 : 三相馬達附剎車器. WITH 3-PHASE BRAKE MOTIOR.

【生活箴言】

逃避不一定能夠躲的過 .
面對不一定就會最難過 .
得到不一定就會最滿足 .
失去不一定就是最損失 .
轉身不一定就是最軟弱 .
挺身不一定就是最堅強 .

【生活箴言】

一. 認真生活 , 一次就足夠 .
二. 低著頭 , 怎麼看得到太陽 .
三. 心量有多大, 世界有多大 .
四. 有想法就要行動, 有行動才會成功 .

2-6 入力法蘭齒輪減速機
FLANGE TYPE REDUCER WITHOR MOTOR



CHM 臥式入力法蘭
CHM HORIZONTAL TYPE



CVM 立式入力法蘭
CVM VERTICAL TYPE

臥式入力法蘭 HORIZONTAL TYPE

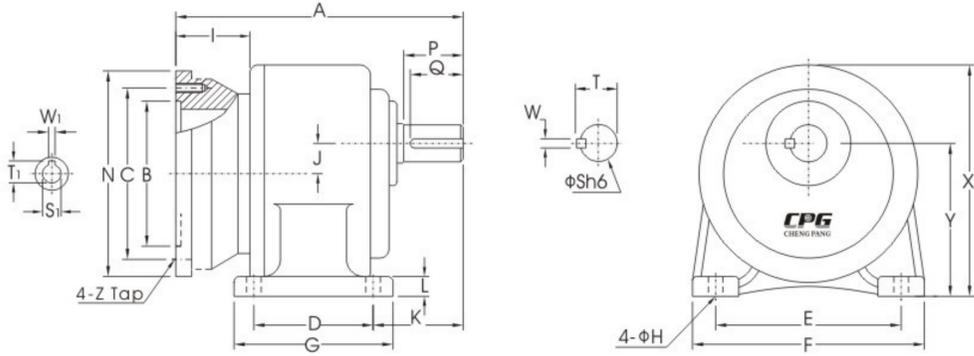

立式入力法蘭 VERTICAL TYPE

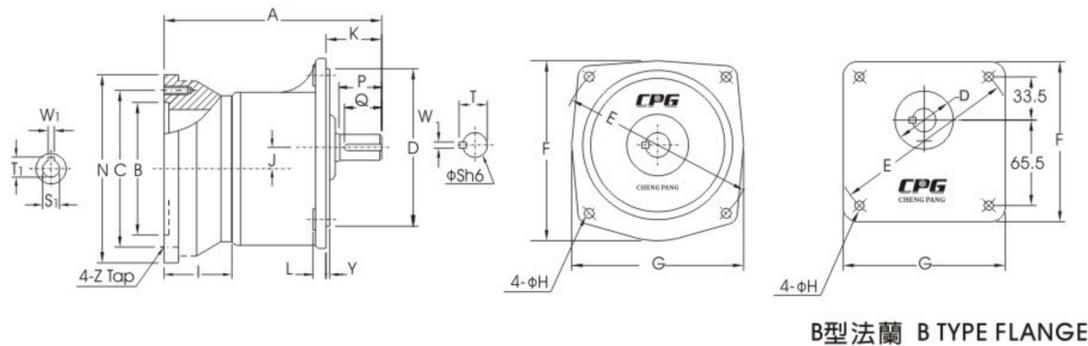

B型法蘭 B TYPE FLANGE

入力孔尺寸 INPUT BORE

馬力 KW	入力孔 BORE		鍵槽 KEYWAY	
	S1	F7	W1	T1
1/4HP	φ11		4	12.8
1/2HP	φ14		5	16.3
1HP	φ19		6	21.8
2HP	φ24		8	27.3
3HP	φ28		8	31.3
5HP	φ28		8	31.3

出力軸尺寸 OUTPUT SHAFT

型番 SIZE(S)	出力軸 SHAFT		鍵槽 KEYWAY			鍵 KEY
	Shφ	P	W	T	Q	SPEC'
18	φ18	30	5	20.2	27	5*5*27
22	φ22	40	7	25	35	7*7*35
28	φ28	45	7	31.1	40	7*7*40
32	φ32	55	10	35.5	50	10*8*50
40	φ40	65	10	43.5	60	10*8*60
50	φ50	80	14	54	75	14*9*75

臥式入力法蘭 HORIZONTAL TYPE (Dimension in mm)

馬力 KW	減速比 RATIO	型番 SIZE(S)	A	B	C	D	E	F	G	H	I	J	K	L	N	X	Y	Z
200W 1/4HP	3-10	18	160	110	130	40	110	135	65	9	55	16	50	10	160	138	88.5	M8
	15-90	22	195	110	130	65	130	158	90	11	55	17.5	60	13	160	152	97.5	M8
	100-200	28	225	110	130	90	140	178	120	12	55	23	68	17	160	178	116	M8
400W 1/2HP	3-10	22	195	110	130	65	130	158	90	11	55	17.5	60	13	160	152	97.5	M8
	15-90	28	225	110	130	90	140	178	120	12	55	23	68	17	160	178	116	M8
	100-200	32	255	110	130	130	170	210	165	13	55	30	70	23	160	212	140	M8
750W 1HP	3-25	28	250	130	165	90	140	178	120	12	82	23	68	17	200	178	116	M10
	30-120	32	285	130	165	130	170	210	165	13	82	30	70	23	200	212	140	M10
	125-200	40	335	130	165	150	210	265	198	15	82	36	89	24	200	250	162	M10
1500W 2HP	3-30	32	285	130	165	130	170	210	165	13	82	30	70	23	200	212	140	M10
	40-100	40	335	130	165	150	210	265	198	15	82	36	89	24	200	250	162	M10
2200W 3HP	3-40	40	355	180	215	150	210	265	198	15	105	36	89	24	250	250	162	M12
	45-100	50	410	180	215	170	265	325	238	18	105	51	120	31.5	250	308	200	M12
3700W 5HP	3-10	40	355	180	215	150	210	265	198	15	105	36	89	24	250	250	162	M12
	15-100	50	410	180	215	170	265	325	238	18	105	51	120	31.5	250	308	200	M12

立式入力法蘭 VERTICAL TYPE (Dimension in mm)

馬力 KW	減速比 RATIO	型番 SIZE(S)	A	B	C	D	E	F	G	H	I	J	K	L	N	Y	Z
200W 1/4HP	3-10	*18	160	110	130	50	140	120	120	9	55	16	38.5	12	160	6	M8
	15-90	22	195	110	130	148	185	175	165	11	55	17.5	48	12	160	3	M8
	100-200	28	225	110	130	170	220	205	195	12	55	23	58	13	160	3	M8
400W 1/2HP	3-10	22	195	110	130	148	185	175	165	11	55	17.5	48	12	160	3	M8
	15-90	28	225	110	130	170	220	205	195	12	55	23	58	13	160	3	M8
	100-200	32	255	110	130	185	255	248	225	15	55	30	65	16	160	3	M8
750W 1HP	3-25	28	250	130	165	170	220	205	195	12	82	23	58	13	200	3	M10
	30-120	32	285	130	165	185	255	248	225	15	82	30	65	16	200	3	M10
	125-200	40	335	130	165	230	310	291	272	15	82	36	85	21	200	5	M10
1500W 2HP	3-30	32	285	130	165	185	255	248	225	15	82	30	65	16	200	3	M10
	40-100	40	335	130	165	230	310	291	272	15	82	36	85	21	200	5	M10
2200W 3HP	3-40	40	355	180	215	230	310	291	272	15	105	36	85	21	250	5	M12
	45-100	50	410	180	215	280	390	372	342	18	105	51	92	25	250	5	M12
3700W 5HP	3-10	40	355	180	215	230	310	291	272	15	105	36	85	21	250	5	M12
	15-100	50	410	180	215	280	390	372	342	18	105	51	92	25	250	5	M12

備註：1. 配合IEC馬達為主。AVAILABLE FOR IEC METRIC MOTOR.
2. *屬於B型出力法蘭。*BELONG TO B TYPE OUTPUT FLANGE.

2-7 入力法蘭高速比齒輪減速機
HIGH RATIO FLANGE TYPE REDUCER WITHOR MOTOR



CHM 臥式入力法蘭高速比
CHM HORIZONTAL HIGH RATIO TYPE



CVM 立式入力法蘭高速比
CVM VERTICAL HIGH RATIO TYPE

臥式入力法蘭高速比 CHM HORIZONTAL HIGH RATIO TYPE

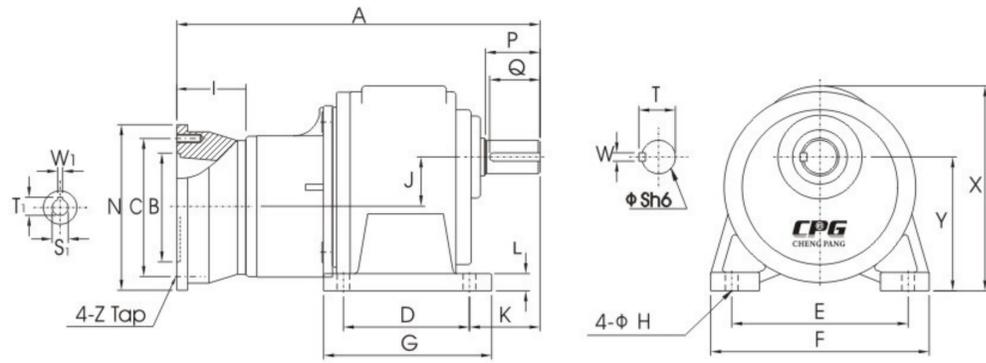

立式入力法蘭高速比 VERTICAL HIGH RATIO TYPE

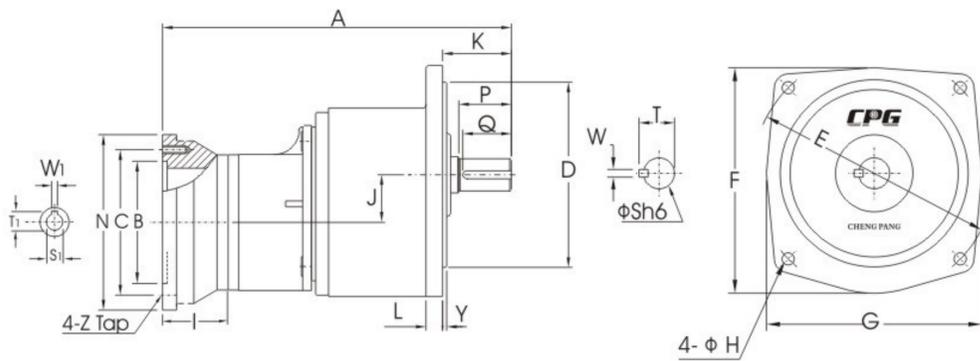

入力孔尺寸 INPUT BORE

馬力 KW	入力孔 BORE		鍵槽 KEYWAY	
	S1	F7	W1	T1
1/4HP	φ11		4	12.8
1/2HP	φ14		5	16.3
1HP	φ19		6	21.8
2HP	φ24		8	27.3

出力軸尺寸 OUTPUT SHAFT

型番 SIZE(S)	出力軸 SHAFT		鍵槽 KEYWAY			鍵 KEY
	S h6	P	W	T	Q	SPEC'
32	φ32	55	10	35.5	50	10*8*50
40	φ40	65	10	43.5	60	10*8*60
50	φ50	80	14	54	75	14*9*75

臥式入力法蘭高速比 CHM HORIZONTAL HIGH RATIO TYPE (Dimension in mm)

馬力 KW	減速比 RATIO	型番 SIZE(S)	A	B	C	D	E	F	G	H	I	J	K	L	N	X	Y	Z
200W 1/4 HP	250-1800	32	335	110	130	130	170	210	165	13	55	47.5	70	23	160	212	140	M8
400W 1/2 HP	250-1800	40	410	110	130	150	210	265	198	15	55	59	89	24	160	250	162	M8
750W 1 HP	250-1800	50	490	130	165	170	265	325	238	18	82	74	120	31.5	200	308	200	M10
1500W 2HP	250-1800	50	515	130	165	170	265	325	238	18	82	81	120	31.5	200	308	200	M10

立式入力法蘭高速比 VERTICAL HIGH RATIO TYPE (Dimension in mm)

馬力 KW	減速比 RATIO	型番 SIZE(S)	A	B	C	D	E	F	G	H	I	J	K	L	N	Y	Z
200W 1/4HP	250-1800	32	335	110	130	185	255	248	225	15	55	47.5	65	16	160	3	M8
400W 1/2HP	250-1800	40	410	110	130	230	310	291	272	15	55	59	85	21	160	5	M8
750W 1 HP	250-1800	50	490	130	165	280	390	372	342	18	82	74	92	25	200	5	M10
1500W 2HP	250-1800	50	515	130	165	280	390	372	342	18	82	81	92	25	200	5	M10

備註：配合IEC馬達為主。AVAILABLE FOR IEC METRIC MOTOR.

【生活箴言】

運用時間去工作，這是成功的代價。
費點時間去思索，這是力量的泉源。
花點時間去遊樂，這是青春的方法。
抽出時間去閱讀，這是智慧的基礎。
勻出時間去愛人，這是快樂的大道。

【生活箴言】

好人藥方
好肚腸一條，慈悲心一片，溫柔半兩，道理三分，信行要緊。
中直一塊，孝順十分，老實一個，陰騭全用，方便不拘多少。

2-8 雙軸齒輪減速機
DOUBLE SHAFT TYPE REDUCER WITHOR MOTOR



CHD 臥式雙軸
CHD HORIZONTAL TYPE



CVD 立式雙軸
CVD VERTICAL TYPE

臥式雙軸 HORIZONTAL TYPE

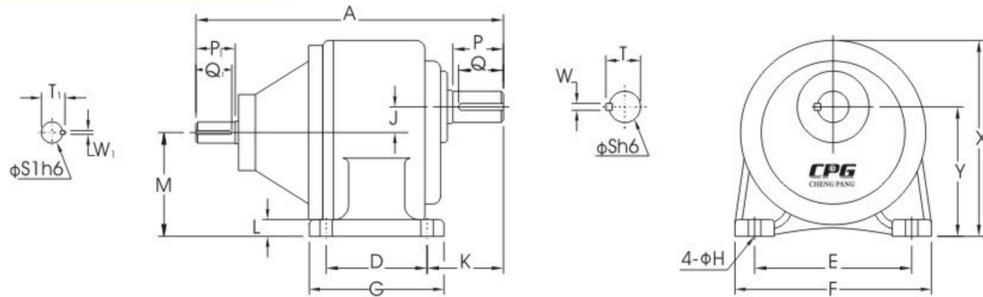

立式雙軸 VERTICAL TYPE

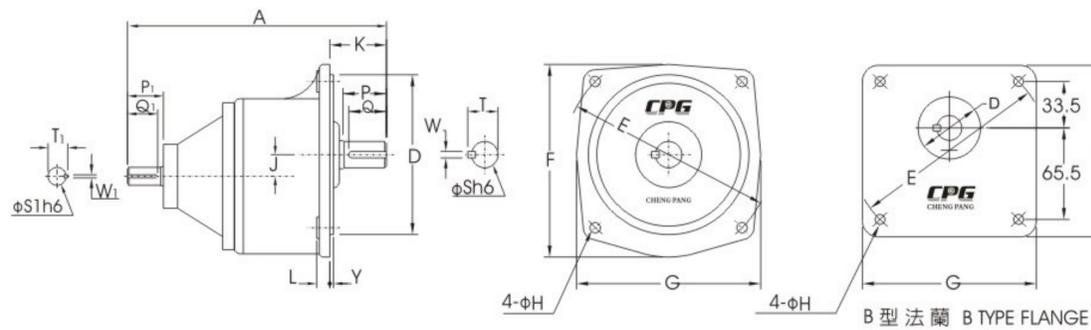

入力軸尺寸 INPUT SHAFT

KW	入力軸 SHAFT		鍵槽 KEYWAY			鍵 KEY
	S1 h6	P1	W1	T1	Q1	SPEC'
0.1/0.2	14	25	5	16.2	22	5*5*22
0.4	16	30	5	18.2	27	5*5*27
0.75	19	40	6	21.7	35	6*6*35
1.5	24	50	8	27.1	45	8*7*45
2.2	28	55	8	31.1	50	8*7*50
3.7	28	55	8	31.1	50	8*7*50

出力軸尺寸 OUTPUT SHAFT

型番 SIZE(S)	出力軸 SHAFT		鍵槽 KEYWAY			鍵 KEY
	S h6	P	W	T	Q	SPEC'
18	φ 18	30	5	20.2	27	5*5*27
22	φ 22	40	7	25	35	7*7*35
28	φ 28	45	7	31.1	40	7*7*40
32	φ 32	55	10	35.5	50	10*8*50
40	φ 40	65	10	43.5	60	10*8*60
50	φ 50	80	14	54	75	14*9*75

臥式雙軸 HORIZONTAL TYPE (Dimension in mm)

馬力 KW	減速比 RATIO	型番 SIZE(S)	A	D	E	F	G	H	J	K	L	M	X	Y
100W 1/8HP	3-50	18	165	40	110	135	65	9	16	50	10	72.5	138	88.5
	60-200	22	195	65	130	158	90	11	17.5	60	13	80	152	97.5
200W 1/4 HP	3-10	18	165	40	110	135	65	9	16	50	10	72.5	138	88.5
	15-90	22	195	65	130	158	90	11	17.5	60	13	80	152	97.5
	100-200	28	230	90	140	178	120	12	23	68	17	93	178	116
		28	260*	90	140	178	120	12	23	68	17	93	178	116
400W 1/2 HP	3-10	22	235	65	130	158	90	11	17.5	60	13	80	152	97.5
	15-90	28	265	90	140	178	120	12	23	68	17	93	178	116
	100-200	32	300	130	170	210	165	13	30	70	23	110	212	140
750W 1 HP	3-25	28	275	90	140	178	120	12	23	68	17	93	178	116
	30-120	32	310	130	170	210	165	13	30	70	23	110	212	140
	125-200	40	365	150	210	265	198	15	36	89	24	126	250	162
1500W 2 HP	3-30	32	320	130	170	210	165	13	30	70	23	110	212	140
	40-100	40	375	150	210	265	198	15	36	89	24	126	250	162
2200W 3 HP	3-40	40	390	150	210	265	198	15	36	89	24	126	250	162
	45-100	50	450	170	265	325	238	18	51	120	31.5	149	308	200
3700W 5 HP	3-10	40	390	150	210	265	198	15	36	89	24	126	250	162
	15-100	50	450	170	265	325	238	18	51	120	31.5	149	308	200

*: 非標規格, 客戶未指定, 不做此規格

立式雙軸 VERTICAL TYPE (Dimension in mm)

馬力 KW	減速比 RATIO	型番 SIZE(S)	A	D	E	F	G	H	J	K	L	Y
100W 1/8HP	3-50	*18	165	50	140	120	120	9	16	38.5	12	6
	60-200	22	195	148	185	175	165	11	17.5	48	12	3
200W 1/4 HP	3-10	*18	165	50	140	120	120	9	16	38.5	12	6
	15-90	22	195	148	185	175	165	11	17.5	48	12	3
	100-200	28	230	170	220	205	195	12	23	58	13	3
		28	260*	170	220	205	195	12	23	58	13	3
400W 1/2 HP	3-10	22	235	148	185	175	165	11	17.5	48	12	3
	15-90	28	265	170	220	205	195	12	23	58	13	3
	100-200	32	300	185	255	248	225	15	30	65	16	3
750W 1 HP	3-25	28	275	170	220	205	195	12	23	58	13	3
	30-120	32	310	185	255	248	225	15	30	65	16	3
	125-200	40	365	230	310	291	272	15	36	85	21	5
1500W 2 HP	3-30	32	320	185	255	248	225	15	30	65	16	3
	40-100	40	375	230	310	291	272	15	36	85	21	5
2200W 3 HP	3-40	40	390	230	310	291	272	15	36	85	21	5
	45-100	50	450	280	390	372	342	18	51	92	25	5
3700W 5 HP	3-10	40	390	230	310	291	272	15	36	85	21	5
	15-100	50	450	280	390	372	342	18	51	92	25	5

備註: 1. * 屬於B型出力法蘭. * BELONG TO B TYPE OUTPUT FLANGE

*: 非標規格, 客戶未指定, 不做此規格

2-9 高速比雙軸齒輪減速機
DOUBLE SHAFT HIGH RATIO TYPE REDUCER WITHOR MOTOR



CHD 臥式高速比雙軸
CHD HORIZONTAL HIGH RATIO TYPE

CVD 立式高速比雙軸
CVD VERTICAL HIGH RATIO TYPE

臥式高速比雙軸 HORIZONTAL HIGH RATIO TYPE

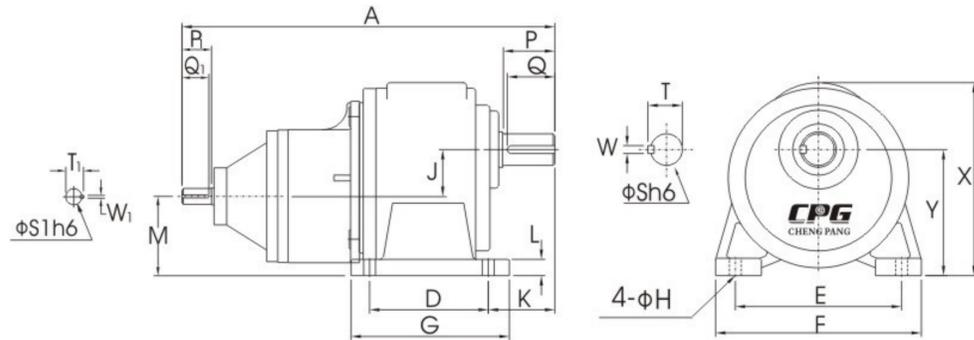

立式高速比雙軸 VERTICAL HIGH RATIO TYPE

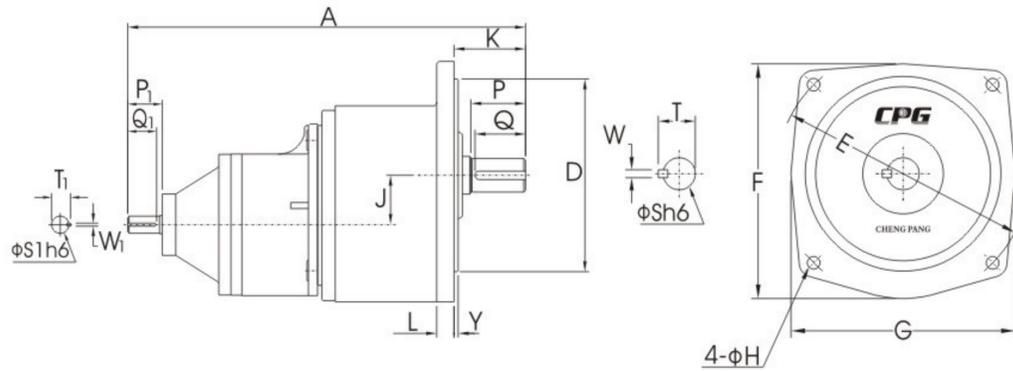

入力軸尺寸 INPUT SHAFT

入力軸 SHAFT	鍵槽 KEYWAY	鍵 KEY
KW	S1 h6	P1 W1 T1 Q1 SPEC'
0.1	14	25 5 16.2 22 5*5*22
0.2	14	25 5 16.2 22 5*5*22
0.4	16	30 5 18.2 27 5*5*27
0.75	19	40 6 21.7 35 6*6*35
1.5	24	50 8 27.1 45 8*8*45

出力軸尺寸 OUTPUT SHAFT

型番 SIZE(S)	出力軸 SHAFT	鍵槽 KEYWAY	鍵 KEY
	Sh6	P W T Q	SPEC'
28	φ 28	45 7 31.1 40	7*7*40
32	φ 32	55 10 35.5 50	10*8*50
40	φ 40	65 10 43.5 60	10*8*60
50	φ 50	80 14 54 75	14*9*75

臥式高速比雙軸 HORIZONTAL HIGH RATIO TYPE (Dimension in mm)

馬力 KW	減速比 RATIO	型番 SIZE(S)	A	D	E	F	G	H	J	K	L	M	X	Y
100W 1/8HP	250-1800	28	290	90	140	178	120	12	39	68	17	77	178	116
200W 1/4 HP	250-1800	32	340	130	170	210	165	13	47.5	70	23	92.5	212	140
400W 1/2 HP	250-1800	40	455	150	210	265	198	15	59	89	24	103	250	162
750W 1 HP	250-1800	50	515	170	265	325	238	18	74	120	31.5	126	308	200
1500W 2HP	250-1800	50	550	170	265	325	238	18	81	120	31.5	119	308	200

立式高速比雙軸 VERTICAL HIGH RATIO TYPE (Dimension in mm)

馬力 KW	減速比 RATIO	型番 SIZE(S)	A	D	E	F	G	H	J	K	L	Y
100W 1/8HP	250-1800	28	290	170	220	205	195	12	39	58	13	3
200W 1/4 HP	250-1800	32	340	185	255	248	225	15	47.5	65	16	3
400W 1/2 HP	250-1800	40	455	230	310	291	272	15	59	85	21	5
750W 1 HP	250-1800	50	515	280	390	372	342	18	74	92	25	5
1500W 2HP	250-1800	50	550	280	390	372	342	18	81	92	25	5

【生活箴言】

長壽十則

少車多步，少欲多施，少怒多笑，少食多嚼，少鹽多醋。
少言多行，少衣多浴，少煩多眠，少糖多果，少肉多菜。

學習

聰明人從別人錯誤中取得教訓。
普通人從自己錯誤中取得教訓。
愚笨人重複錯誤無法取得教訓。

為善

人為善，福雖未至，禍已遠離。
人為惡，禍雖未至，福已遠離。

說話

多說話不如少說話，少說話不如說好話。

2-10 附單相鋁殼/半密鐵殼(剎車)馬達減速機
ATTACHED TO THE SINGLE-PHASE ALUMINIUM SHELL/HALF CLOSE IRON SHELLS (BRAKE) MOTOR REDUCER



CH..A 臥式附單相 HORIZONTAL SINGLE-PHASE ALUMINIUM SHELL
 CV..A 立式附單相鋁殼 VERTICAL ENCLOSED SINGLE-PHASE ALUMINIUM SHELL

臥式附單相 HORIZONTAL ENCLOSED SINGLE-PHASE ALUMINIUM SHELL

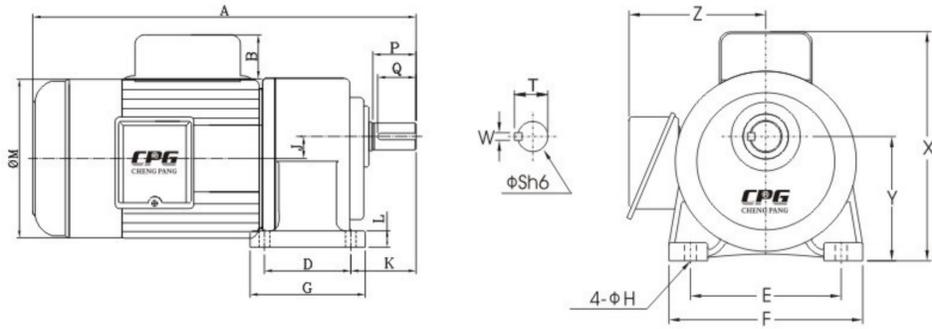

立式附單相 VERTICAL ENCLOSED SINGLE-PHASE ALUMINIUM SHELL

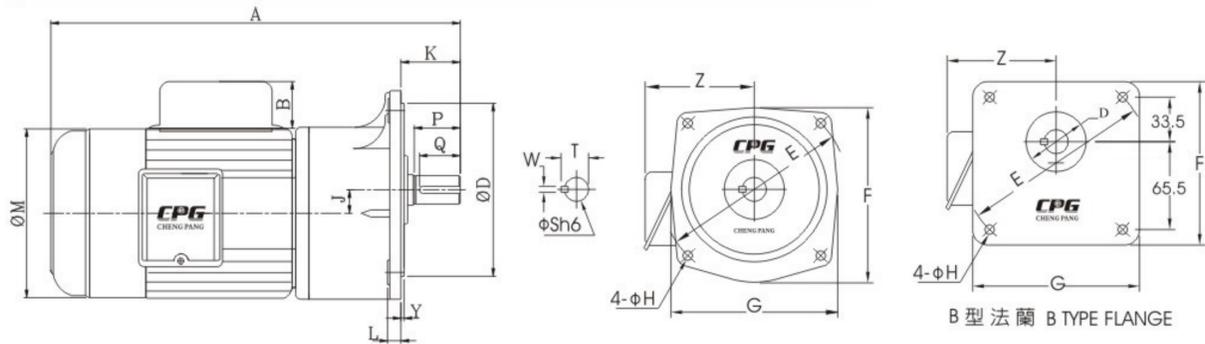

出力軸尺寸 OUTPUT SHAFT

型番 SIZE(S)	出力軸 SHAFT		鍵槽 KEYWAY			鍵 KEY
	Sh6	P	W	T	Q	SPEC'
18	φ18	30	5	20.2	27	5*5*27
22	φ22	40	7	25	35	7*7*35
28	φ28	45	7	31.1	40	7*7*40
32	φ32	55	10	35.5	50	10*8*50
40	φ40	65	10	43.5	60	10*8*60
50	φ50	80	14	54	75	14*9*75

適用機型 APPLICABLE MODELS : CH..AT , CH..ATB , CV..AT , CV..ATB

臥式附單相半密 HORIZONTAL TYPE (Dimension in mm)

馬力 KW	減速比 RATIO	本體 CODE	型番 SIZE(S)	A	B	D	E	F	G	H	J	K	L	M	X	Y	Z
100W 1/8 HP	3-50	1#	18	250		40	110	135	65	9	16	50	10	133	138	88.5	120
	60-200	2#	22	280		65	130	158	90	11	17.5	60	13	133	152	97.5	120
200W 1/4 HP	3-10	1#	18	285		40	110	135	65	9	16	50	10	133	138	88.5	120
	15-90	2#	22	315		65	130	158	90	11	17.5	60	13	133	152	97.5	120
	100-200	3#	28	350		90	140	178	120	12	23	68	17	133	178	116	120
400W 1/2 HP	3-10	2#	22	375	50	65	130	158	90	11	17.5	60	13	167	215	97.5	135
	15-90	3#	28	405	50	90	140	178	120	12	23	68	17	167	230	116	135
	100-200	4#	32	440	50	130	170	210	165	13	30	70	23	167	245	140	135
750W 1 HP	3-25	3#	28	425	50	90	140	178	120	12	23	68	17	167	230	116	135
	30-120	4#	32	455	50	130	170	210	165	13	30	70	23	167	245	140	135
	125-200	5#	40	510	50	150	210	265	198	15	36	89	24	167	260	162	135
1500W 2 HP	3-30	4#	32	470	50	130	170	210	165	13	30	70	23	192	260	140	146
	40-100	5#	40	530	50	150	210	265	198	15	36	89	24	192	275	162	146
	105-120	6#	50	580	50	170	265	325	238	18	51	120	31.5	192	308	200	146

立式附單相半密 VERTICAL TYPE (Dimension in mm)

馬力 KW	減速比 RATIO	本體 CODE	型番 SIZE(S)	A	B	D	E	F	G	H	J	K	L	M	Y	Z
100W 1/8 HP	3-50	1#	*18	250		50	140	120	120	9	16	38.5	12	133	6	120
	60-200	2#	22	280		148	185	175	165	11	17.5	48	12	133	3	120
200W 1/4 HP	3-10	1#	*18	285		50	140	120	120	9	16	38.5	12	133	6	120
	15-90	2#	22	315		148	185	175	165	11	17.5	48	12	133	3	120
	100-200	3#	28	350		170	220	205	195	12	23	58	13	133	3	120
400W 1/2 HP	3-10	2#	22	375	50	148	185	175	165	11	17.5	48	12	167	3	135
	15-90	3#	28	405	50	170	220	205	195	12	23	58	13	167	3	135
	100-200	4#	32	440	50	185	255	248	225	15	30	65	16	167	3	135
750W 1 HP	3-25	3#	28	425	50	170	220	205	195	12	23	58	13	167	3	135
	30-120	4#	32	455	50	185	255	248	225	15	30	65	16	167	3	135
	125-200	5#	40	510	50	230	310	291	272	15	36	85	21	167	5	135
1500W 2 HP	3-30	4#	32	470	50	185	255	248	225	15	30	65	16	192	3	146
	40-100	5#	40	530	50	230	310	291	272	15	36	85	21	192	5	146
	105-120	6#	50	580	50	280	390	372	342	18	51	92	25	192	5	146

備註：1. 單相剎車馬達尺寸另議。CONTACT FOR BRAKE TYPE DIMENSIONS.

2. * 屬於B型出力法蘭。* BELONG TO B TYPE OUTPUT FLANGE

2-11 附單相縮框鋁殼/半密鐵殼(剎車)馬達減速機
WITH SINGLE BOX ALUMINUM SHELL/HALF CLOSE IRON SHELLS (BRAKE) MOTOR REDUCER



CH..AZ 臥式附單相縮框 CH..AZ HORIZONTAL WITH SINGLE BOX ALUMINUM SHELL
CV..AZ 立式附單相縮框鋁殼 CV..AZ VERTICAL ENCLOSED SINGLE-PHASE BOX ALUMINUM SHELL

臥式附單相縮框 HORIZONTAL WITH SINGLE PHASE REDUCTION BOX ALUMINUM SHELL

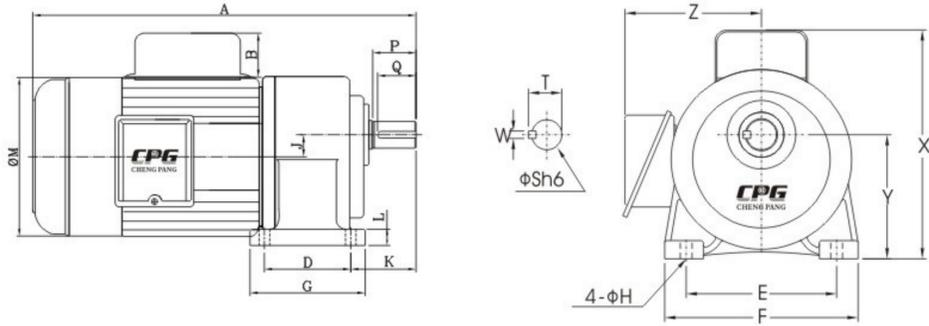

立式附單相縮框 VERTICAL ENCLOSED SINGLE-PHASE BOX ALUMINUM SHELL

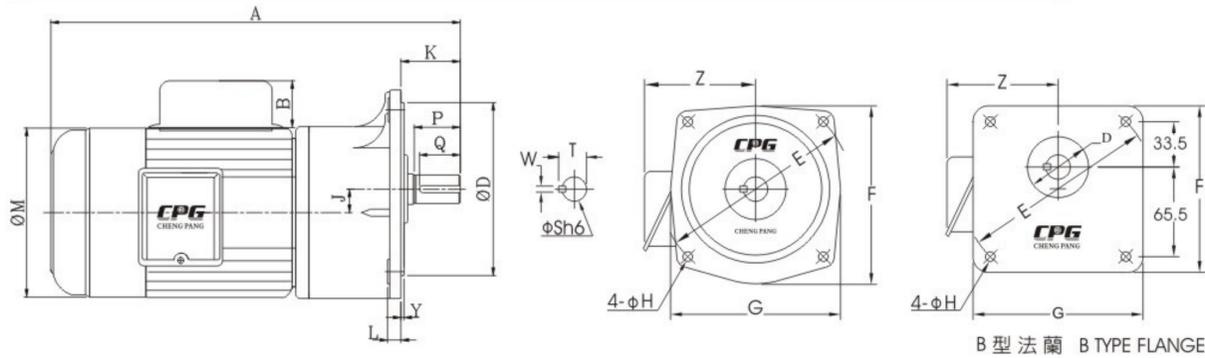

出力軸尺寸 OUTPUT SHAFT

型番 SIZE(S)	出力軸 SHAFT		鍵槽 KEYWAY			鍵 KEY
	Sh6	P	W	T	Q	SPEC'
18	φ18	30	5	20.2	27	5*5*27
22	φ22	40	7	25	35	7*7*35
28	φ28	45	7	31.1	40	7*7*40
32	φ32	55	10	35.5	50	10*8*50
40	φ40	65	10	43.5	60	10*8*60

適用機型 APPLICABLE MODELS : CH..ATZ , CH..ATZB , CV..ATZ , CV..ATZB

臥式附單相縮框半密 HORIZONTAL LIGHT DUTY TYPE (Dimension in mm)

馬力 KW	減速比 RATIO	本體 CODE	型番 SIZE(S)	A	B	D	E	F	G	H	J	K	L	M	X	Y	Z
100W 1/8 HP	60-160	1#	18	260		40	110	135	65	9	16	50	10	133	138	88.5	120
200W 1/4 HP	15-90	1#	18	295		40	110	135	65	9	16	50	10	133	138	88.5	120
	100-200	2#	22	315		65	130	158	90	11	17.5	60	13	133	152	97.5	120
400W 1/2 HP	15-90	2#	22	375	50	65	130	158	90	11	17.5	60	13	167	215	97.5	135
	100-175	3#	28	405	50	90	140	178	120	12	23	68	17	167	230	116	135
750W 1 HP	3-25	2#	22	395	50	65	130	158	90	11	17.5	60	13	167	215	97.5	135
	30-120	3#	28	425	50	90	140	178	120	12	23	68	17	167	230	116	135
	125-200	4#	32	455	50	130	170	210	165	13	30	70	23	167	245	140	135
	3-30	3#	28	440	50	90	140	178	120	12	23	68	17	192	240	116	146
1500W 2 HP	40-100	4#	32	470	50	130	170	210	165	13	30	70	23	192	260	140	146
	110-180	5#	40	530	50	150	210	265	198	15	36	89	24	192	275	162	146

立式附單相縮框半密 VERTICAL LIGHT DUTY TYPE (Dimension in mm)

馬力 KW	減速比 RATIO	本體 CODE	型番 SIZE(S)	A	B	D	E	F	G	H	J	K	L	M	Y	Z
100W 1/8 HP	60-160	1#	*18	260		50	140	120	120	9	16	38.5	12	133	6	120
200W 1/4 HP	15-90	1#	*18	295		50	140	120	120	9	16	38.5	12	133	6	120
	100-200	2#	22	315		148	185	175	165	11	17.5	48	12	133	3	120
400W 1/2 HP	15-90	2#	22	375	50	148	185	175	165	11	17.5	48	12	167	3	135
	100-175	3#	28	405	50	170	220	205	195	12	23	58	13	167	3	135
750W 1 HP	3-25	2#	22	395	50	148	185	175	165	11	17.5	48	12	167	3	135
	30-120	3#	28	425	50	170	220	205	195	12	23	58	13	167	3	135
	125-200	4#	32	455	50	185	255	248	225	15	30	65	16	167	3	135
	3-30	3#	28	440	50	170	220	205	195	12	23	58	13	192	3	146
1500W 2 HP	40-100	4#	32	470	50	185	255	248	225	15	30	65	16	192	3	146
	110-180	5#	40	530	50	230	310	291	272	15	36	85	21	192	5	146

備註：單相剎車馬達尺寸另議，CONTACT FOR BRAKE TYPE DIMENSIONS .

*屬於B型出力法蘭 . * BELONG TO B TYPE OUTPUT FLANGE .

2-12 附東元鐵殼(剎車)馬達減速機
WITH STEEL PLATE TECO (BRAKE) MOTOR



CH..P 臥式附東元
CH..P HORIZONTAL TYPE



CV..P 立式附東元
CV..P VERTICAL TYPE

臥式附東元 HORIZONTAL TYPE

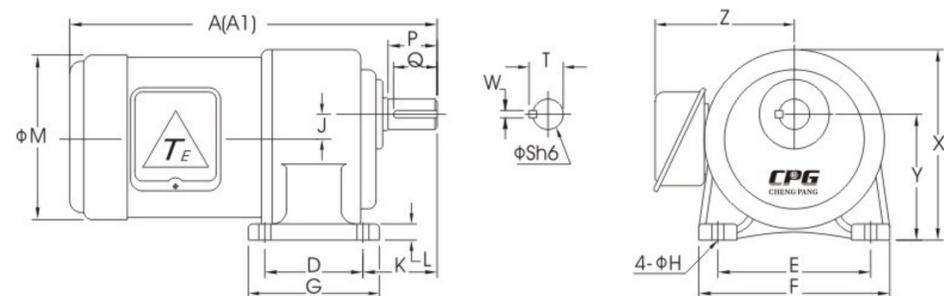

立式附東元 VERTICAL TYPE

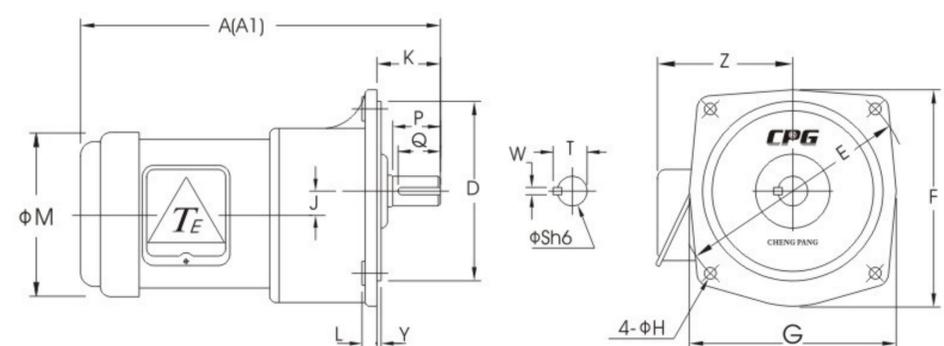

出力軸尺寸 OUTPUT SHAFT

型番 SIZE(S)	出力軸 SHAFT		鍵槽 KEYWAY			鍵 KEY
	Sh6	P	W	T	Q	SPEC'
22	φ22	40	7	25	35	7*7*35
28	φ28	45	7	31.1	40	7*7*40
32	φ32	55	10	35.5	50	10*8*50
40	φ40	65	10	43.5	60	10*8*60
50	φ50	80	14	54	75	14*9*75

適用機型 APPLICABLE MODELS : CH..P, CH..PB, CV..P, CV..PB

臥式附東元 HORIZONTAL TYPE (Dimension in mm)

馬力 KW	減速比 RATIO	本體 CODE	型番 SIZE(S)	A	A1	D	E	F	G	H	J	K	L	M	X	Y	Z
200W 1/4 HP	3-90	2#	22	320	320	65	130	158	90	11	17.5	60	13	131	152	97.5	130
	100-200	3#	28	350	350	90	140	178	120	12	23	68	17	131	178	116	130
400W 1/2 HP	3-10	2#	22	330	330	65	130	158	90	11	17.5	60	13	144	152	97.5	135
	15-90	3#	28	360	360	90	140	178	120	12	23	68	17	144	178	116	135
750W 1 HP	100-200	4#	32	390	390	130	170	210	165	13	30	70	23	144	212	140	135
	3-25	3#	28	375	375	90	140	178	120	12	23	68	17	163	178	116	150
1500W 2 HP	30-120	4#	32	410	410	130	170	210	165	13	30	70	23	163	212	140	150
	125-200	5#	40	460	460	150	210	265	198	15	36	89	24	163	250	162	150
	3-30	4#	32	450	450	130	170	210	165	13	30	70	23	184	212	140	162
1500W 2 HP	40-100	5#	40	500	500	150	210	265	198	15	36	89	24	184	250	162	162
	105-120	6#	50	560	560	170	265	325	238	18	51	120	31.5	184	308	200	162

立式附東元 VERTICAL TYPE (Dimension in mm)

馬力 KW	減速比 RATIO	本體 CODE	型番 SIZE(S)	A	A1	D	E	F	G	H	J	K	L	M	Y	Z
200W 1/4 HP	3-90	2#	22	320	320	148	185	175	165	11	17.5	48	12	131	3	130
	100-200	3#	28	350	350	170	220	205	195	12	23	58	13	131	3	130
400W 1/2 HP	3-10	2#	22	330	330	148	185	175	165	11	17.5	48	12	144	3	135
	15-90	3#	28	360	360	170	220	205	195	12	23	58	13	144	3	135
750W 1 HP	100-200	4#	32	390	390	185	255	248	225	15	30	65	16	144	3	135
	3-25	3#	28	375	375	170	220	205	195	12	23	58	13	163	3	150
1500W 2 HP	30-120	4#	32	410	410	185	255	248	225	15	30	65	16	163	3	150
	125-200	5#	40	460	460	230	310	291	272	15	36	85	21	163	5	150
1500W 2 HP	3-30	4#	32	450	450	185	255	248	225	15	30	65	16	184	3	162
	40-100	5#	40	500	500	230	310	291	272	15	36	85	21	184	5	162
	105-120	6#	50	560	560	280	390	372	342	18	51	92	25	184	5	162

備註 : A : 三相鐵殼東元馬達 . WITH 3-PHASE TECO MOTOR .

A1 : 三相鐵殼東元馬達附剎車器 . WITH 3-PHASE TECO BRAKE MOTOR .

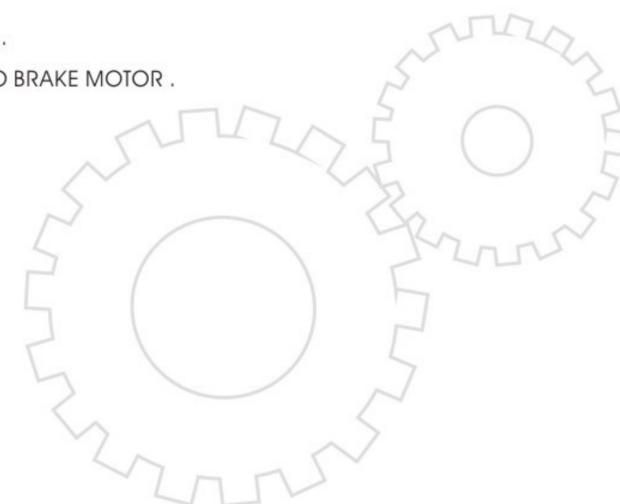

2-13 附三相鋁/鐵殼減速機附DC24V送電剎車器
WITH ALUMINUM/STEEL PLATE 3-PHASE MOTOR W/DC24V POWER FOR BRAKE UNIT



CH..SD 臥式附三相
CH..SD HORIZONTAL TYPE



CV..SD 立式附三相
CV..SD VERTICAL TYPE

臥式附三相 HORIZONTAL TYPE

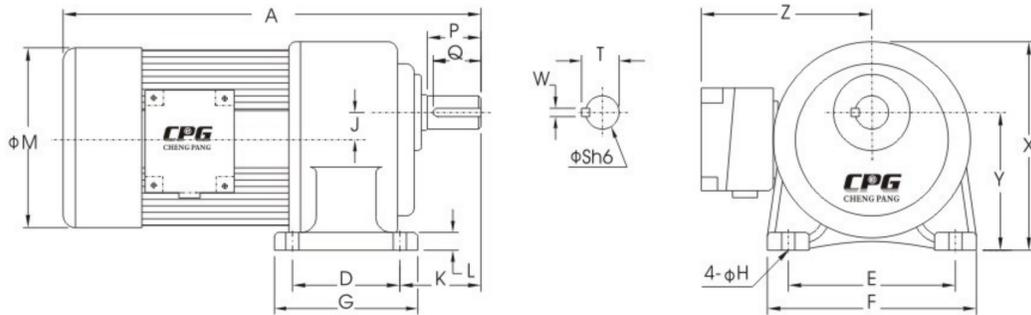

立式附三相 VERTICAL TYPE

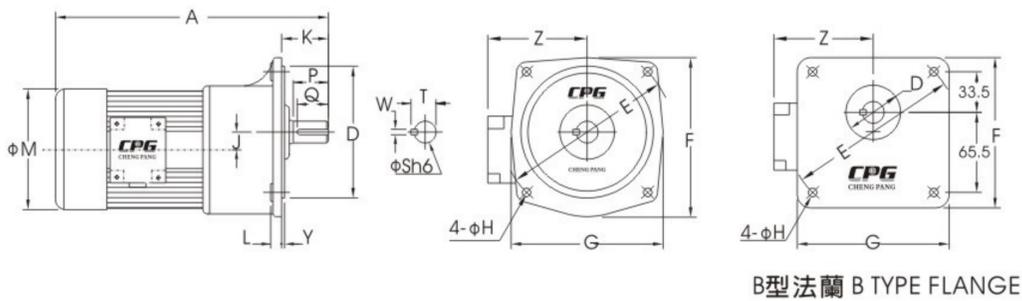

出力軸尺寸 OUTPUT SHAFT

型番 SIZE(S)	出力軸 SHAFT		鍵槽 KEYWAY			鍵 KEY
	Sh6	P	W	T	Q	SPEC'
18	φ18	30	5	20.2	27	5*5*27
22	φ22	40	7	25	35	7*7*35
28	φ28	45	7	31.1	40	7*7*40
32	φ32	55	10	35.5	50	10*8*50
40	φ40	65	10	43.5	60	10*8*60
50	φ50	80	14	54	75	14*9*75

適用機型 APPLICABLE MODELS : CH..SD , CH..STD , CV..SD , CV..STD

臥式附三相 HORIZONTAL TYPE (Dimension in mm)

馬力 KW	減速比 RATIO	剎車器 BRAKE TYPE	型番 SIZE(S)	A	D	E	F	G	H	J	K	L	M	X	Y	Z
100W 1/8HP	3-50	S 50	18	280	40	110	135	65	9	16	50	10	133	138	88.5	120
	60-200		22	310	65	130	158	90	11	17.5	60	13	133	152	97.5	120
200W 1/4HP	3-10	M10	18	315	40	110	135	65	9	16	50	10	133	138	88.5	120
	15-90		22	345	65	130	158	90	11	17.5	60	13	133	152	97.5	120
	100-200		28	375	90	140	178	120	12	23	68	17	133	178	116	120
400W 1/2HP	3-10	M10	22	360	65	130	158	90	11	17.5	60	13	167	*152	97.5	135
	15-90		28	390	90	140	178	120	12	23	68	17	167	178	116	135
	100-200		32	425	130	170	210	165	13	30	70	23	167	212	140	135
750W 1HP	3-25	M20	28	420	90	140	178	120	12	23	68	17	167	178	116	135
	30-120		32	455	130	170	210	165	13	30	70	23	167	212	140	135
	125-200		40	510	150	210	265	198	15	36	89	24	167	250	162	135
1500W 2HP	3-30	M20	32	500	130	170	210	165	13	30	70	23	192	212	140	146
	40-100		40	550	150	210	265	198	15	36	89	24	192	250	162	146
	105-120		50	605	170	265	325	238	18	51	120	31.5	192	308	200	146

* : 減速機高度152,風罩到腳座底部高度為163.

立式附三相 VERTICAL TYPE (Dimension in mm)

馬力 KW	減速比 RATIO	剎車器 BRAKE TYPE	型番 SIZE(S)	A	D	E	F	G	H	J	K	L	M	Y	Z
100W 1/8HP	3-50	S 50	*18	280	50	140	120	120	9	16	38.5	12	133	6	120
	60-200		22	310	148	185	175	165	11	17.5	48	12	133	3	120
200W 1/4HP	3-10	M10	*18	315	50	140	120	120	9	16	38.5	12	133	6	120
	15-90		22	345	148	185	175	165	11	17.5	48	12	133	3	120
	100-200		28	375	170	220	205	195	12	23	58	13	133	3	120
400W 1/2HP	3-10	M10	22	360	148	185	175	165	11	17.5	48	12	167	3	135
	15-90		28	390	170	220	205	195	12	23	58	13	167	3	135
	100-200		32	425	185	255	248	225	15	30	65	16	167	3	135
750W 1HP	3-25	M20	28	420	170	220	205	195	12	23	58	13	167	3	135
	30-120		32	455	185	255	248	225	15	30	65	16	167	3	135
	125-200		40	515	230	310	291	272	15	36	85	21	167	5	135
1500W 2HP	3-30	M20	32	500	185	255	248	225	15	30	65	16	192	3	146
	40-100		40	550	230	310	291	272	15	36	85	21	192	5	146
	105-120		50	605	280	390	372	342	18	51	92	25	192	5	146

備註 : 1. 送電剎車電壓為 DC24V. DC24V POWER FOR BRAKE UNIT

2. *屬於B型出力法蘭. *BELONG TO B TYPE OUTPUT FLANGE.

2-14-1 CV..S 立式標準IEC三相鋁殼(剎車)馬達
CV..S IEC VERTICAL 3-PHASE ALUMINUM (BRAKE) MOTOR

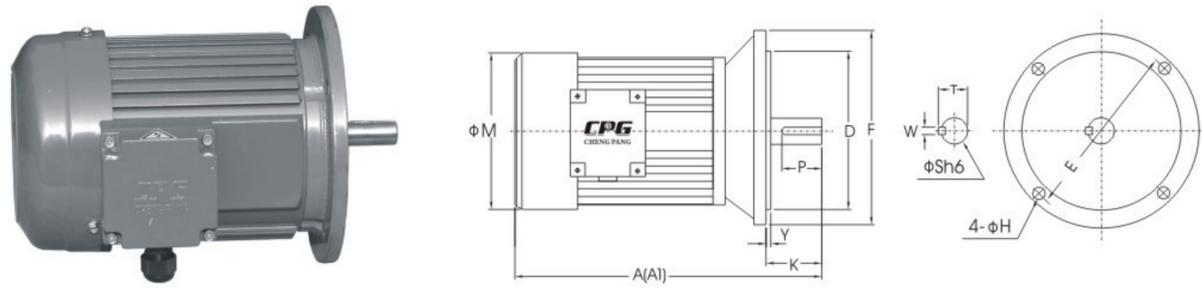

適用機型 APPLICABLE MODELS : CV..S, CV..SB, CV..ST, CV..STB

Dimension in mm

輸出馬力 CAPACITY	框號 FRAME	A	A1	D	E	F	H	K	M	P	Sh6	T	W	Y	重量(KG) WEIGHT
4P															
1/8HP	---	210	210	95	115	140	10	23	133	20	11	12.5	4	3.5	4.4
1/4HP	63	240	240	95	115	140	10	23	133	20	11	12.5	4	3.5	5.9
1/2HP	71	290	290	110	130	160	10	30	143	25	14	16	5	3.5	10.6
1HP	80	285	285	130	165	200	12	40	167	35	19	21.5	6	3.5	13.0
2HP	90L	370	370	130	165	200	12	50	192	45	24	27	8	3.5	21.5
3HP	100L	410	410	180	215	250	14.5	60	220	50	28	31	8	4	28.0
5HP	112L	450	450	180	215	250	14.5	60	220	50	28	31	8	4	34.5

A1 : 三相鋁框馬達附剎車器 . WITH 3-PHASE ALUMINUM BRAKE MOTOR .

2-14-2 CV..S 立式三相鋁殼(剎車)馬達——城邦規格
CV..S VERTICAL 3-PHASE ALUMINUM (BRAKE) MOTOR——CHENG PANG

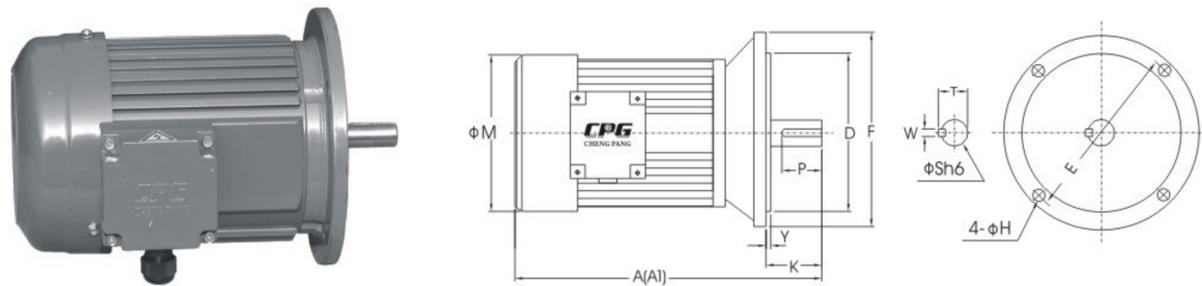

適用機型 APPLICABLE MODELS : CV..S, CV..SB, CV..ST, CV..STB

Dimension in mm

輸出馬力 CAPACITY	框號 FRAME	A	A1	D	E	F	H	K	M	P	Sh6	T	W	Y	重量(KG) WEIGHT
4P															
1/8HP	----	210	210	110	130	160	10	23	133	20	11	12.5	4	3.5	6.8
1/4HP	----	240	240	110	130	160	10	23	133	20	11	12.5	4	3.5	8.1

A1 : 三相鋁框馬達附剎車器 . WITH 3-PHASE ALUMINUM BRAKE MOTOR .

2-14-3 CV..S 立式三相鋁殼(剎車)馬達——B14
CV..S VERTICAL 3-PHASE ALUMINUM (BRAKE) MOTOR——B14

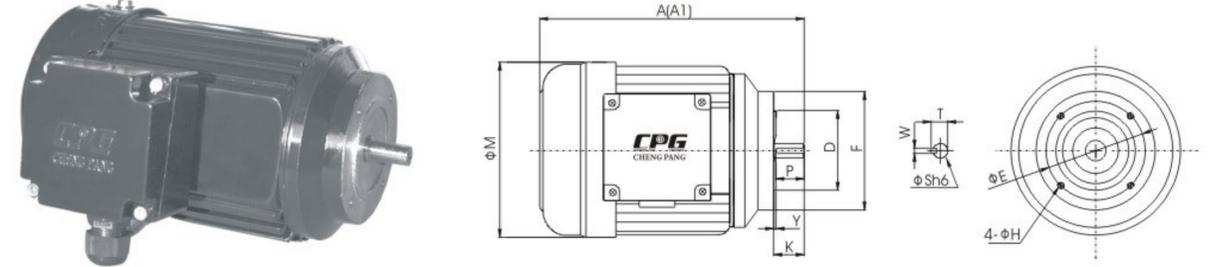

適用機型 APPLICABLE MODELS : CV..S, CV..SB, CV..ST, CV..STB

Dimension in mm

輸出馬力 CAPACITY	框號 FRAME	A	A1	D	E	F	H	K	M	P	Sh6	T	W	Y	重量(KG) WEIGHT
4P															
1/8HP	---	210	210	60	75	90	M5	23	133	20	11	12.5	4	1.8	4.2
1/4HP	63	240	240	60	75	90	M5	23	133	20	11	12.5	4	1.8	5.7
1/2HP	71	290	290	70	85	105	M6	30	143	25	14	16	5	2.5	8.2
1HP	80	285	285	80	100	120	M6	40	167	35	19	21.5	6	3	13
2HP	90L	370	370	95	115	140	M8	50	192	45	24	27	8	3	19

A1 : 三相鋁框馬達附剎車器 . WITH 3-PHASE ALUMINUM BRAKE MOTOR .

2-15 CV..AT 立式單相鐵殼(剎車)馬達
CV..AT VERTICAL 1-PHASE STEEL PLATE (BRAKE) MOTOR

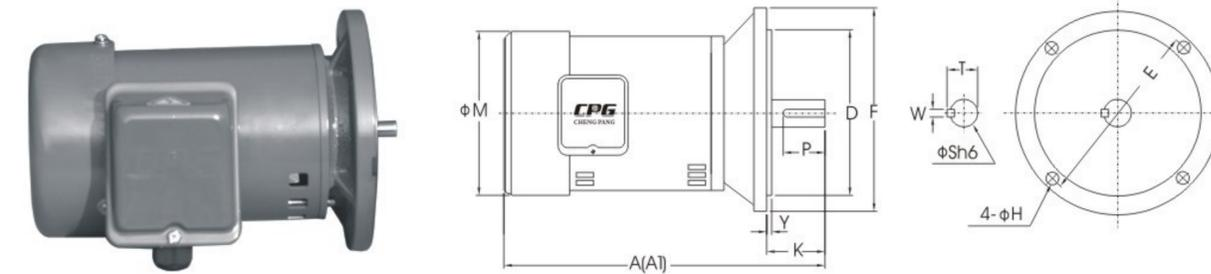

適用機型 APPLICABLE MODELS : CV..AT, CV..ATB, CV..A, CV..AB

Dimension in mm

輸出馬力 CAPACITY	框號 FRAME	A	A1	D	E	F	H	K	M	P	Sh6	T	W	Y	重量 WEIGHT
4P															
1/8HP	--	204	----	110	130	160	10	23	127	20	11	12.5	4	3.5	7.0
1/4HP	63	238	----	110	130	160	10	23	127	20	11	12.5	4	3.5	8.2
1/2HP	80	254	284	130	165	200	12	40	167	35	19	21.5	6	3.5	9.1
1HP	80	281	311	130	165	200	12	40	167	35	19	21.5	6	3.5	11.5

備註 : 1. A=單相電機型 FOR CAPACITOR RUNNING
 2. A1=單相離心開關機型 FOR CENTRIFUGAL RUNNING
 3. 剎車馬達尺寸另議 CONTACT FOR BRAKE TYPE DIMENSIONS

2-16 W./CV..S 蝸輪減速機配立式齒輪減速機
W./CV..S WORM GEAR REDUCER WITH VERTICAL GEARMOTOR .

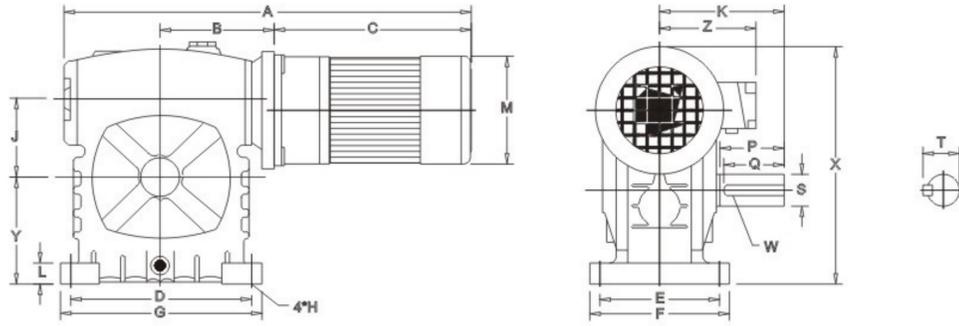

出力軸尺寸 OUTPUT SHAFT								
TYPE	出力軸 SHAFT	Sh6	P	W	T	Q	鍵槽 KEYWAY	鍵 KEY
60#	Sh6	22	50	7	25	45		7*7*45
70#	Sh6	28	60	7	31.1	55		7*7*55
80#	Sh6	32	65	10	35.5	60		10*8*60
100#	Sh6	38	75	10	41	70		10*8*70

適用機型 APPLICABLE MODELS : W./CV..S,W./CV..A

Dimension in mm

蝸輪機型 WORM REDUCER	蝸輪本體 (GEARMOTOR)			A	A1	B	C	D	E	F	G	H	J	K	L	M	X	Y
	馬力 KW(HP)	型番 SIZE	減速比 RATIO															
60#-1/30	100W (1/8HP)	1#-φ18	1/3-50	383	383	98	208	120	105	131	154	11	60	112	16	133	195	90
	100W (1/8HP)	1#-φ18	1/3-50	428	428	125	208	150	115	152	190	15	70	130	20	133	220	105
70#-1/30	200W (1/4HP)	1#-φ18	1/3-10	465	465	128	242	150	115	152	190	15	70	130	20	133	220	105
		2#-φ22	1/15-30	489	489	128	266	150	115	152	190	15	70	130	20	133	262	105
	400W (1/2HP)	1#-φ18	1/3-10	502	502	128	279	150	115	152	190	15	70	130	20	167	262	105
		2#-φ22	1/3-10	529	529	140	279	180	135	172	220	15	80	143	20	167	287	120
80#-1/30	100W (1/8HP)	1#-φ18	1/3-50	455	455	137	208	180	135	172	220	15	80	143	20	133	245	120
		1#-φ18	1/3-10	492	492	140	242	180	135	172	220	15	80	143	20	133	245	120
	200W (1/4HP)	1#-φ18	1/3-10	516	516	140	266	180	135	172	220	15	80	143	20	133	287	120
		2#-φ22	1/15-90	516	516	140	266	180	135	172	220	15	80	143	20	133	287	120
100#-1/30	200W (1/4HP)	2#-φ22	*1/5-10	572	572	170	266	220	155	194	272	15	100	171	25	133	337	150
		2#-φ22	1/15-90	572	572	170	266	220	155	194	272	15	100	171	25	133	337	150
	400W (1/2HP)	1#-φ18	1/3-10	585	585	170	279	220	155	194	272	15	100	171	25	167	337	150
		1#-φ18	1/15-60	608	608	175	297	220	155	194	272	15	100	171	25	167	353	150
		3#-φ22	1/3-25	625	625	175	322	220	155	194	272	15	100	171	25	167	353	150

備註：*必需使用加大2#本體。* IT MUST USE ENLARGE 2#GEAR HOUSING.

3-1 剎車零件分解圖
SECTIONAL DIAGRAM FOR BRAKE UNIT

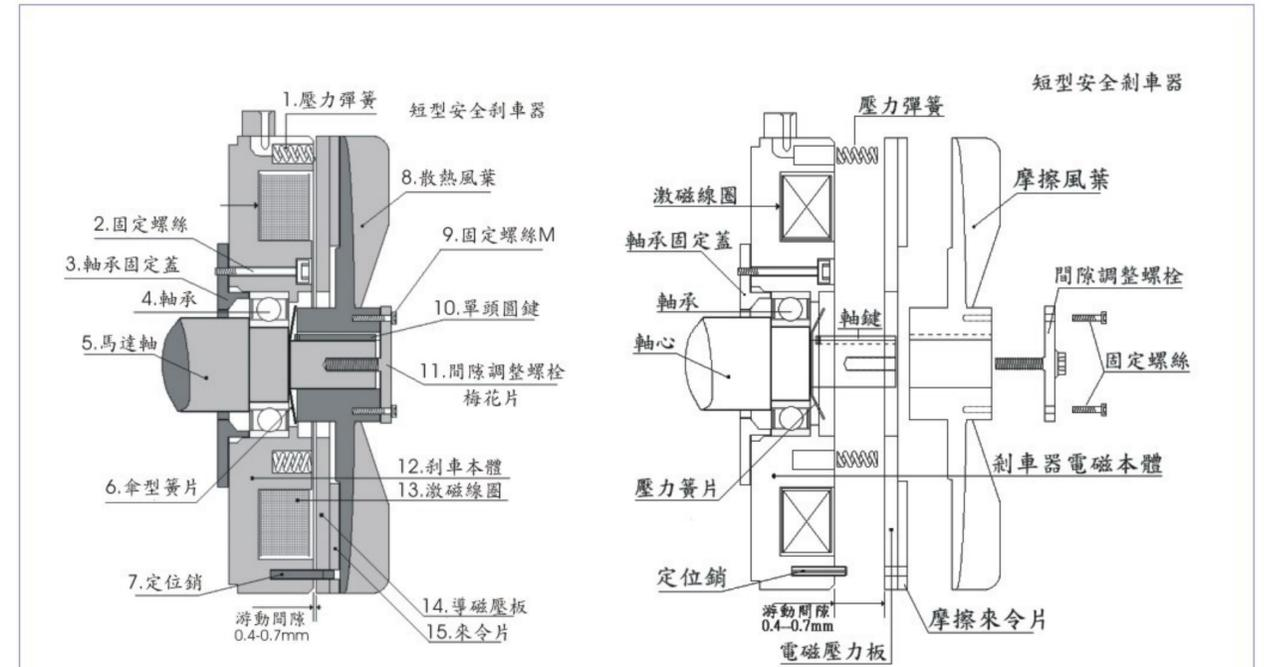

1	壓力彈簧 PRESSURE SPRING	9	固定螺絲 FIXED SCREW
2	固定螺絲 FIXED SCREW	10	固定鍵 KEY
3	軸承固定蓋 FIXED BEARING PLATE	11	調整螺栓 GAP ADJUSTMENT BOLT
4	軸承 BEARING	12	剎車本體 BRAKE HOUSING
5	馬達軸 MOTOR SHAFT	13	激磁線圈 BRAKE COIL
6	傘型簧片 DISC SPRING	14	導磁壓板 FRICTION PLATE
7	定位銷 FIXED PIN	15	來令片 FRICTION BRAKE DISC
8	散熱風葉 FAN		

剎車間隙調整 ADJUST BRAKE CLEARANCE

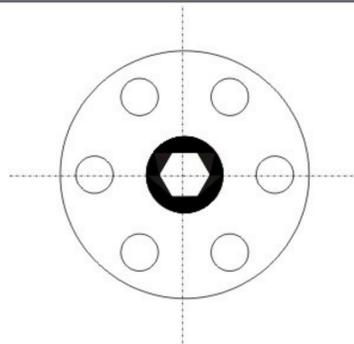

1. 請先移除固定螺絲。
PLEASE REMOVE TWO PIECES FIXED SCREWS IN ADVANCE .
2. 每向右調整一格,其間距縮小0.07-0.10 mm。
EVERY SINGLE POSITION ADJUSTMENT , BRAKE CLEARANCE WILL REDUCE 0.07-0.10 mm

3-2 零件剖面圖 SECTIONAL DIAGRAM FOR PARTS

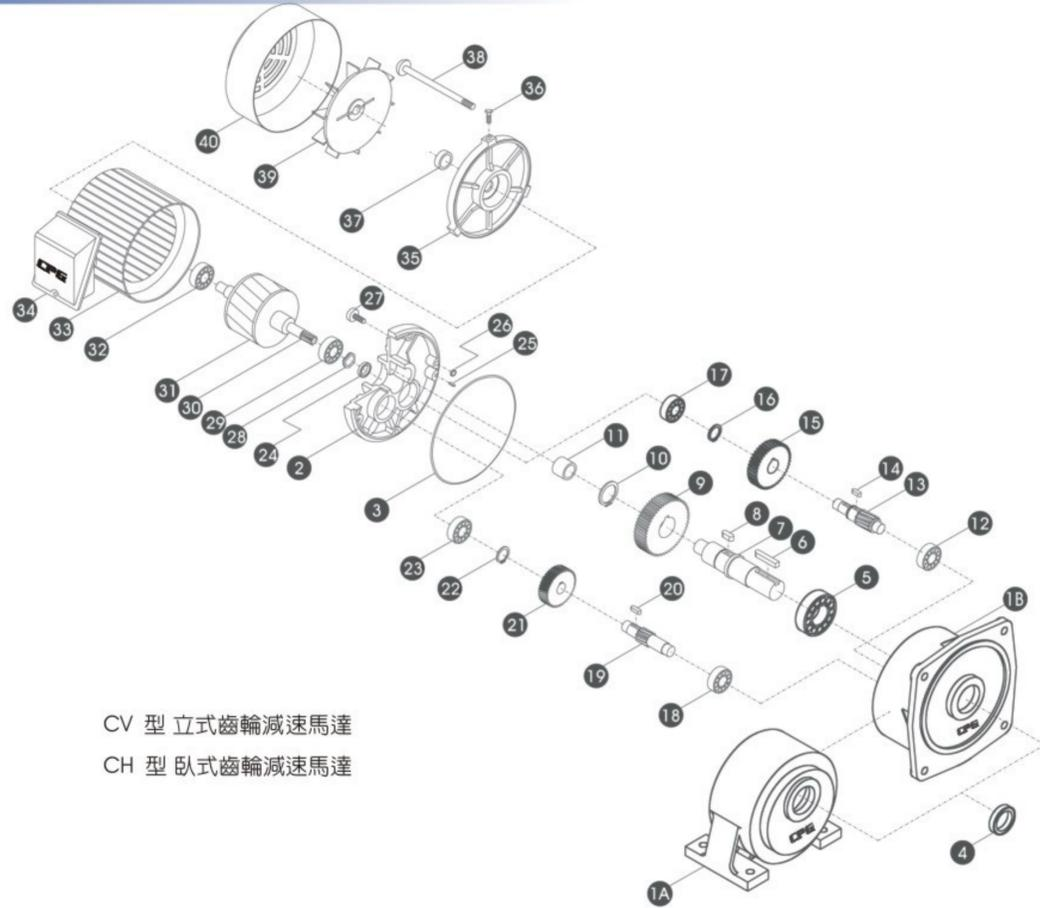

CV 型 立式齒輪減速馬達
CH 型 臥式齒輪減速馬達

2段/3段式結構剖示圖
2 STAGES / 3 STAGES SECTIONAL DIAGRAM

項次	零件名稱	項次	零件名稱	項次	零件名稱
1A	臥式本體 HORIZONTAL HOUSING	14	三段小齒軸鍵 KEY-3 RD STAGE PINION	28	波浪彈簧 WAVE SPRING
1B	立式本體 VERTICAL HOUSING	15	二段大齒輪 GEAR-2 ND STAGE	29	馬達軸培林BEARING- MOTOR SHAFT
2	馬達前蓋HOUSING COVER	16	C-扣環 SNAP RING	30	馬達齒軸 MOTOR SHAFT
3	O型環 O-RING	17	三段齒軸培林 BEARING-3 RD STAGE PINION	31	轉子ROTOR
4	出力軸油封 OIL SEAL-OUTPUT SHAFT	18	二段齒軸培林 BEARING-2 ND STAGE PINION	32	馬達軸培林BEARING- MOTOR SHAFT
5	出力軸培林 BEARING-OUTPUT SHAFT	19	二段小齒軸 PINION-2 ND STAGE	33	線圈總成 COIL ASSEMBLY
6	出力軸鍵 KEY-OUTPUT SHAFT	20	二段小齒軸鍵 KEY-2 ND STAGE PINION	34	鋁接線盒WIRE BOX
7	出力軸OUTPUT SHAFT	21	一段大齒輪 GEAR-1 ST STAGE	35	馬達後蓋 REAR COVER-MOTOR
8	三段小齒軸鍵 KEY-3 RD PINION	22	C-扣環 SNAP RING	36	風罩螺絲 SCREW-FAN COVER
9	三段大齒輪 GEAR-3 RD STAGE	23	二段齒軸培林 BEARING-2 ND STAGE PINION	37	後蓋油封 OIL SEAL-REARCOVER
10	C-扣環 SNAP RING	24	入力側油封 OIL SEAL-MOTOR SHAFT	38	馬達螺栓 BOLT-MOTOR
11	出力軸自潤軸承 OILLESS BEARING	25	定位銷 PIN	39	風葉 FAN
12	二段齒軸培林 BEARING-2 ND STAGE PINION	26	O型環 O-RING	40	風罩 FAN COVER-MOTOR
13	三段小齒軸 PINION-3 RD STAGE	27	內六角螺絲 HEX-HEAD SCREW		

3-3 減速機各部零件說明 PARTS DETAILS

A) 本體 (HOUSING)

- * 1號, 2號及3號本體.其出力軸直徑介於 $\phi 18 - \phi 28$ 之間時, 減速機本體皆採用鋁合金材質ADC-12.
ALUMINUM HOUSING FOR OUTPUT SHAFT DIAMETER BETWEEN $\phi 18 \sim \phi 28$.
HOUSING MATERIAL : ADC-12 ALUMINUM ALLOY .
- * 4號, 5號及6號本體.其出力軸直徑介於 $\phi 32 \sim \phi 50$ 之間時, 減速機本體皆採用鑄鐵材質FC-20.
CAST IRON HOUSING FOR OUTPUT SHAFT DIAMETER BETWEEN $\phi 32 \sim \phi 50$.
HOUSING MATERIAL : FC-20 CAST IRON .

B)1/2/3段齒輪 (1ST , 2ND & 3RD STAGE GEAR)

- * 齒輪經精密滾齒加工, 齒輪加工精度等級為2-3級.
GEAR MACHINING BY PRECISION HOBBIING MACHINE , GEAR PRECISION LEVEL BETWEEN GRADE 2 - 3 .
- * 齒輪材質為S45C, 調質至HRC 21° 再經高週波熱處理至HRC 45°~48°
GEAR WITH S45C MATERIAL . BY NORMALIZE & INDUCTION HARDENED HEAT TREATMENT TO HARDNESS HRC 45°~48°

C)二/三段齒軸 (2ND & 3RD STAGE PINION)

- * 齒軸經SKIVING精密滾齒加工, 齒輪精度等級為1-2級.
GEAR PINION MACHINING BY SKIVING CUTTING , PINION PRECISION LEVEL BETWEEN GRADE 1 - 2 .
- * 齒軸材質為SCM21, 調質至HRC 21° 再經滲碳熱處理至HRC 58°~61°
PINION WITH SCM21 MATERIAL . BY NORMALIZE & CARBONIZE HARDENED HEAT TREATMENT TO HARDNESS HRC 58°~61°

D)馬達齒軸 (MOTOR SHAFT)

- * 馬達齒軸經SKIVING精密滾齒加工, 齒軸精度等級為1-2級.
MOTOR SHAFT GEAR PINION MACHINING BY SKIVING CUTTING , PINION PRECISION LEVEL BETWEEN GRADE 1 - 2 .
- * 材質為SCM4, 調質至HRC 21° 再經高週波熱處理至HRC 50°~53°
PINION WITH SCM4 MATERIAL . BY NORMALIZE & INDUCTION HARDENED HEAT TREATMENT TO HARDNESS HRC 50°~53°

E)軸承 (BEARING)

- * 馬達部份皆採用瑞典SKF或同等級精密軸承, 以確保長期運轉壽命 .
ALL MOTOR SHAFT ASSEMBLY WITH SWEDEN MADE "SKF" BEARING OR EQUIVALENT
PRECISION BEARING . IN ORDER TO ENSURE LONG LIFE RUNNING..

F)油封 (OIL SEAL)

- * 馬達軸側以耐高溫VITON油封為主, 可確保防止潤滑油回漏馬達內部 .
MOTOR SHAFT SIDE WITH "VITON" MATERIAL OIL SEAL . IT CAN PREVENT LUBRICANT FLOW INTO MOTOR CASING .

G)接線盒 (TERMINAL BOX)

- * 採用鋁合金專用IP-55鋁製接線盒, 防水性及防塵性佳 .
TERMINAL BOX WITH ALUMINUM ALLOY MATERIAL . SPECIAL DESIGN FOR IP-55 LEVEL AND TOTALLY AVOID WATER AND DUST INTO CASING .

H)三相/單相馬達本體 (THREE / SINGLE PHASE MOTOR HOUSING)

- * 三相馬達: 採標準全密閉型專用鋁殼馬達配IP-55鋁製接線盒, 具較佳防水性及防塵性, 易散熱及運轉效率高 .
THREE PHASE MOTOR WITH TOTALLY ENCLOSED FAN COOLED TYPE , IP-55 ALUMINUM TERMINAL BOX TOTALLY AVOID WATER AND DUST INTO HOUSING .
- * 單相馬達: 採標準半密閉型專用鐵殼馬達配鐵製接線盒, 較易散熱, 運轉效率高. (本公司亦可提供全密閉型鐵殼馬達及鋁合金型單相馬達).
SINGLE PHASE MOTOR WITH SEMI-ENCLOSED FAN COOLED STEEL PLATE TYPE . HIGH-EFFICIENCY RUNNING . (ALSO AVAILABLE FOR TOTALLY ENCLOSED STEEL PLATE HOUSING & ALUMINUM TYPE HOUSING)

I)馬達後蓋 (REAR MOTOR COVER)

- * 可採用防水型馬達後蓋, 於軸心處加置油封. 可防止灰塵及外部水氣流入馬達 .
REAR MOTOR COVER ASSEMBLY WITH OIL SEAL . IT CAN PREVENT DUST AND WATER GET INTO MOTOR .

4-1 馬達規範 MOTOR SPECIFICATION

4-1-1 標準馬達規範表 STANDARD MOTOR SPECIFICATION

項目ITEM	三相交流馬達3-PHASE MOTOR		單相交流馬達1-PHASE MOTOR	
保護等級 PROTECTION	全密閉外扇型IP-54 TOTALLY ENCLOSED FAN COOLED TYPE		半密閉外扇型 SEMI-ENCLOSED FAN COOLED TYPE	
外殼材質 HOUSING MATERIAL	0.1-3.7KW	鋁合金 ALUM ALLOY	0.1-1.5KW	鐵殼 STEEL PLATE
	0.1-3.7KW	鐵殼 STEEL PLATE	0.1-1.5KW (OPTIONAL)	鋁合金 ALUM ALLOY
啟動方式 STARTING	全壓啟動 DIRECT START		0.1-0.2KW	運轉電容啟動 CAPACITOR
			0.4-1.5KW	起動電容啟動+離心開關 Capacitor & centrifugal switch
定格 TIME RATING	連續運轉 CONTINUOUS RUNNING		連續運轉 CONTINUOUS RUNNING	
絕緣等級 INSULATION	F-絕緣 F-CLASS		F-絕緣 F-CLASS	
適用環境 ENVIRONMENT	溫度：-10°C TO +40°C (TEMPERATURE BETWEEN -10°C AND +40°C) 濕度：90%以下 (HUMIDITY LESS THAN 90%)			
適用電壓 VOLTAGE	50HZ	220V,230V,240V,380V,400V,415V,440V	50HZ	110V,115V,200V,220V,230V
	60HZ	220V,240V,380V,415V,440V,460V,480V,600V	60HZ	110V,220V,240V
適用極數 POLE	2P,4P,6P,8P		4P	
輸出轉數(4P) FULL SPEED	50HZ	1360-1430RPM	50HZ	1340-1400RPM
	60HZ	1640-1740RPM	60HZ	1610-1720RPM
依據標準 STANDARD	國際/國家標準 IEC-34,CNS-10919 ACCORDING TO IEC-34,CNS-10919			
海拔 SEA LEVEL	1000公尺以下 UNDER 1000M			
接線盒 TERMINAL BOX	採用IP55級防水型鋁合金接線盒 WITH IP-55 CLASS WATER-PROOF ALUMINUM TERMINAL BOX			

4-1-2 三相電壓全負載電流值 3-PHASE/4-POLES FULL LOAD AMPERE

輸出馬力 CAPACITY	50HZ-4P					60HZ				
	220V	380V	415V	440V	RPM	220V	380V	440V	460V	RPM
100W	0.60	0.40	0.32	0.30	1410	0.6	0.35	0.30	0.29	1720
200W	1.15	0.67	0.61	0.58	1410	1.1	0.63	0.55	0.52	1720
400W	2.14	1.24	1.13	1.07	1420	1.9	1.10	0.95	0.91	1730
750W	3.67	2.13	1.94	1.84	1420	3.4	1.96	1.70	1.63	1730
1500W	6.59	3.82	3.49	3.30	1430	6.1	3.53	3.05	2.92	1740
2200W	8.94	5.18	4.74	4.47	1430	8.7	5.04	4.35	4.16	1740
3700W	13.85	8.03	7.34	6.93	1440	13.5	7.82	6.75	6.46	1745

4-1-3 單相電壓全負載電流值 1-PHASE/4-POLES FULL LOAD AMPERE

輸出馬力 CAPACITY	50HZ-4P			60HZ-4P		
	110V	220V	RPM	110V	220V	RPM
100 W	4.00	2.00	1410	3.80	1.90	1720
200 W	5.00	2.50	1410	4.60	2.30	1720
400 W	8.40	4.20	1420	7.80	3.90	1730
750 W	14.20	7.10	1420	12.90	6.40	1730
1500 W	26.00	13.00	1430	23.40	11.70	1740

4-1-4 單相馬達電容器規格 1-PHASE MOTOR CAPACITOR

輸出馬力 CAPACITY	運轉電容(文電型) RUNNING CAPACITOR (NON-CENTRIFUGAL TYPE)	起動電容(離心開關型) STARTING CAPACITOR (THE CENTRIFUGAL SWITCH TYPE)	運轉電容 + 起動電容 (離心開關型) RUNNING & STATING (THE CENTRIFUGAL SWITCH TYPE)
100 W	10 μf-450v	----	----
200 W	16 μf-450v	125 μf-250v	----
400 W	30 μf-450v	----	30 μf-450v+200 μf-250v
750 W	35 μf-450v	----	35 μf-450v+300 μf-250v
1500W	----	----	50 μf-450v+400 μf-250v

4-2 輸出扭矩表 OUTPUT TORQUE

標準型 (NORMAL DUTY TYPE)

KG-M

減速比 RATIO	輸出轉速 OUTPUT R.P.M		輸出扭矩 OUTPUT TORQUE													
			0.1KW		0.2KW		0.4KW		0.75KW		1.5KW		2.2KW		3.7KW	
	HZ															
	50	60	50	60	50	60	50	60	50	60	50	60	50	60	50	60
3	500	600	0.19	0.16	0.37	0.31	0.70	0.60	1.30	1.10	2.60	2.20	3.80	3.20	6.00	5.50
5	300	360	0.31	0.26	0.62	0.52	1.20	1.00	2.20	1.90	4.50	3.80	6.72	5.60	11.0	10.0
10	150	180	0.62	0.52	1.24	1.04	2.40	2.00	4.50	3.80	9.10	7.60	13.7	11.2	22.0	20.0
15	100	120	0.91	0.76	1.80	1.50	3.60	3.00	6.80	5.70	13.5	11.3	20.1	16.8	32.6	29.8
20	75	90	1.20	1.00	2.40	2.00	4.80	4.00	9.00	7.50	18.1	15.1	26.8	22.4	43.6	36.0
25	60	72	1.40	1.20	3.00	2.50	6.00	5.00	11.2	9.40	22.6	18.9	33.6	28.0	53.9	49.53
30	50	60	1.80	1.50	3.60	3.00	7.20	6.00	13.5	11.3	27.1	22.6	40.3	33.6	64.7	58.8
40	37	45	2.20	1.90	4.60	3.90	9.30	7.80	17.5	14.6	34.9	29.1	52.0	43.4	86.3	78.4
45	33	40	2.70	2.20	5.40	4.40	10.9	9.10	20.6	17.0	41.1	34.0	59.8	49.6	98.5	81.7
50	30	36	2.80	2.40	5.70	4.80	11.6	9.70	21.9	18.3	43.6	36.4	65.1	54.3	107	97.0
60	25	30	3.40	2.90	6.90	5.80	13.9	11.6	26.2	21.9	52.4	43.7	78.1	65.1	127	115
70	21	25	4.30	3.60	8.00	6.80	16.2	13.5	31.5	26.3	62.4	52.0	92.5	77.1		
80	19	23	4.80	4.00	9.20	7.70	18.4	15.4	35.5	29.6	70.8	59.0	105	87.5		
90	17	20	5.20	4.40	10.3	8.60	20.7	17.3	39.3	32.8	77.1	64.3	113	94.3		
100	15	18	5.80	4.90	11.5	9.60	23.0	19.2	43.2	36.0	83.7	69.8	126	105		
120	12	15	6.90	5.80	13.8	11.5	27.7	23.1	51.8	43.2	101	83.7				
140	11	13	8.00	6.70	16.0	13.4	32.0	26.7	59.7	49.8						
160	9	11	9.10	7.60	18.3	15.3	36.3	30.3	68.0	56.7						
180	8	10	10.3	8.60	20.7	17.3	40.8	34.0	76.8	64.0						
200	7	9	11.6	9.70	22.9	19.1	43.2	36.0	82.8	69.0						

4-3 出力軸懸垂荷重 OVERHUNG LOAD

KG

減速比 RATIO	輸出轉速 OUTPUT R.P.M		0.1KW		0.2KW		0.4KW		0.75KW		1.5KW		2.2KW		3.7KW	
			HZ													
	50	60	50	60	50	60	50	60	50	60	50	60	50	60	50	60
	3	500	600	30	25	30	25	54	45	60	50	145	130	165	150	200
5	300	360	36	30	36	30	78	70	85	75	165	150	210	180	270	225
10	150	180	70	60	70	60	150	130	165	150	280	250	430	360	570	550
15	100	120	110	90	110	100	170	160	175	160	355	348	490	450	780	750
20	75	90	150	125	135	125	180	170	190	170	369	365	540	500	850	830
25	60	72	155	140	150	140	185	180	210	180	450	430	650	630	1100	1050
30	50	60	160	150	170	165	235	220	415	400	480	450	690	650	1200	1100
40	38	45	160	160	180	180	270	260	430	420	580	550	710	670	1280	1200
45	33	40	170	170	180	180	335	328	440	430	590	570	820	780	1300	1250
50	30	36	170	170	180	180	350	335	450	440	600	580	850	820	1400	1350
60	25	30	180	180	180	180	350	350	450	450	630	610	900	900	1400	1400
70	21	25	180	180	180	180	350	350	460	460	670	650	1100	1100		
80	18	22	180	180	180	180	350	350	460	460	680	680	1100	1100		
90	16	20	180	180	180	180	350	350	500	500	850	850	1200	1200		
100	15	18	200	200	250	250	380	380	590	590	900	900	1200	1200		
120	12	15	200	200	320	320	390	390	640	640	920	920				
140	11	13	200	200	320	320	400	400	679	679	920	920				
150	10	12	220	220	330	330	420	420	679	679	950	950				
160	9	11	220	220	330	330	420	420	700	700	950	950				
180	8	10	240	240	350	350	430	430	720	720	980	980				
200	7	9	240	240	350	350	430	430	720	720						
1/250 ~ 1/1800			300	300	480	480	720	720	1400	1400						

4-4 出力軸允許最大軸徑 AVAILABLE MAX OUTPUT SHAFT DIAMETER

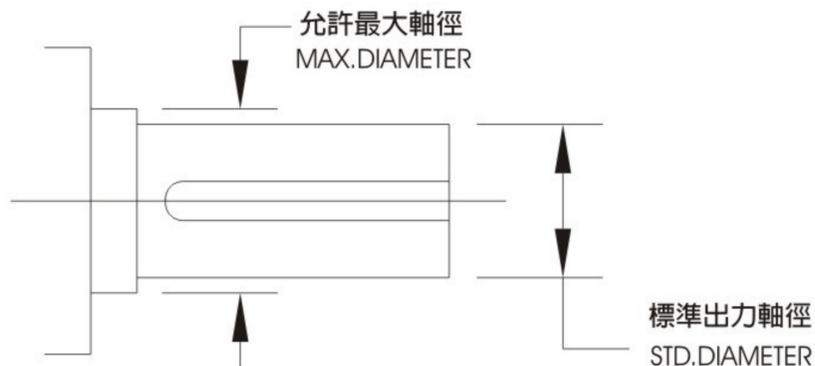

本體框號 HOUSING CODE	標準出力軸徑 STD OUTPUT SHAFT	出力軸培林 OUTPUT SHAFT BEARING	允許最大軸徑 MAX AVAILABLE SHAFT DIAMETER
1#	φ 18.0	6004	φ 20.0
2#	φ 22.0	6205	φ 25.0
3#	φ 28.0	6206	φ 30.0
4#	φ 32.0	6207	φ 35.0
5#	φ 40.0	6209	φ 45.0
6#	φ 50.0	6211	φ 55.0

4-5 軸端攻牙 OUTPUT SHAFT TAPPING

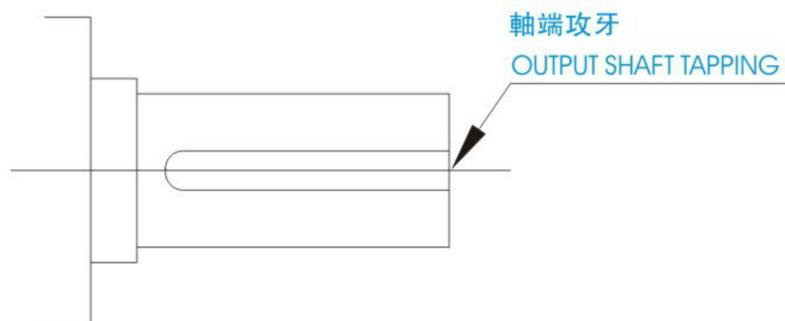

本體框號 HOUSING CODE	軸徑 SHAFT	軸端攻牙 OUTPUT SHAFT TAPPING
1#	φ 18.0	M6×1.0×15
2#	φ 22.0	M8×1.25×15
3#	φ 28.0	M10×1.5×20
4#	φ 32.0	M10×1.5×20
5#	φ 40.0	M12×1.75×25
6#	φ 50.0	M12×1.75×25

客戶未指定時，均不攻牙. NON-APPOINTED NO TAPPING

4-6 出力軸軸徑對照表 OUTPUT SHAFT DIAMETER TABLE

標準型 (NORMAL DUTY TUPE)

速比 RATIO	馬力 CAPACITY	1/8HP (100W)	1/4HP (200W)	1/2HP (400W)	1HP (750W)	2HP (1500W)	3HP (2200W)	5HP (3700W)
3		18	18	22	28	32	40	40
5		18	18	22	28	32	40	40
10		18	18	22	28	32	40	40
15		18	22	28	28	32	40	50
20		18	22	28	28	32	40	50
25		18	22	28	28	32	40	50
30		18	22	28	32	32	40	50
40		18	22	28	32	40	40	50
45		18	22	28	32	40	50	50
50		18	22	28	32	40	50	50
60		22	22	28	32	40	50	50
70		22	22	28	32	40	50	
80		22	22	28	32	40	50	
90		22	22	28	32	40	50	
100		22	28	32	32	40	50	
120		22	28	32	32	50		
140		22	28	32	40	50		
150		22	28	32	40	*50		
160		22	28	32	40	*50		
180		22	28	32	40	*50		
200		22	28	32	40			
250-1800		28	32	40	50			

輕負載縮框型 (LIGHT DUTY TYPE)

速比 RATIO	馬力 CAPACITY	1/8HP (100W)	1/4HP (200W)	1/2HP (400W)	1HP (750W)	2HP (1500W)	3HP (2200W)	5HP (3700W)
3					22	28		
5					22	28		
10					22	28		
15			18	22	22	28		40
20			18	22	22	28		40
25			18	22	22	28		40
30			18	22	28	28		40
40			18	22	28	32		40
45			18	22	28	32		40
50			18	22	28	32	40	40
60		18	18	22	28	32	40	40
70		18	18	22	28	32	40	
80		18	18	22	28	32	40	
90		18	18	22	28	32		
100		18	22	28	28	32		
120		18	22	28	28	40		
140		18	22	28	32	40		
150		18	22	28	32	40		
160		18	22	28	32	40		
180		*18	22	28	32	*40		
200		*18	22	*28	*32			
250-1800		22	28	32	40			

備註
REMARK

- 縮框機型為不正當設計使用，如非必要請勿選用。
LIGHT DUTY TYPE ARE NOT AVAILABLE FOR STANDARD APPLICATION DESIGN, IT ONLY SUITABLE FOR SPECIAL PROJECT DESIGN.
- 僅就馬達部份提供一年保固。PROVIDE ONE YEAR GUARANTEE FOR MOTOR ONLY.
- * 為達到此速比時，必須搭配6P馬達使用。* IT NEED TO USE 6 POLE MOTOR TO REACH CERTAIN RATIO.

4-7 公稱及實際速比 (NORMAL RATIO & ACTUAL RATIO)

標準型 (NORMAL DUTY TYPE)

公稱速比 NORMAL RATIO	低段實際減速比 ACTUAL RATIO						
	0.1KW	0.2KW	0.4KW	0.75KW	1.5KW	2.2KW	3.7KW
3	3.04	3.04	2.99	2.92	3.05	3.25	3.25
5	5.07	5.07	5.14	5.03	5.01	5.19	5.19
10	10.03	10.03	10.01	9.96	10.41	9.48	9.48
15	15.09	15.60	15.61	15.31	14.33	15.71	14.62
20	19.90	19.90	20.69	19.49	19.35	19.38	19.58
25	26.81	25.65	26.35	25.27	25.08	23.71	24.54
30	30.06	32.77	29.81	30.00	29.38	29.25	30.87
40	40.33	40.46	39.11	40.99	43.72	41.83	41.77
50	50.59	49.42	50.21	51.24	50.96	50.51	50.51
60	58.64	63.02	61.36	58.10	61.83	58.48	58.48
70	71.62	71.31	71.15	72.00	72.87	67.65	
80	80.19	81.23	77.13	79.99	80.30	81.18	
90	91.34	92.69	94.27	90.00	90.54	93.99	
100	102.27	104.62	103.70	99.99	103.05	98.17	
110		109.02		108.00	***109.20		
115	115.71				117.00		
120	117.73	123.33	116.66	120.00	122.20		
130	131.81	133.25	129.62	133.79	***126.30		
140	134.34	141.32	140.00				
150	150.41	150.74		150.41	***151.56		
160	162.73	162.86	155.55	160.70	***158.30		
170	168.40	172.73			***175.50		
180	182.19	182.32	175.00	180.01	***183.30		
200	192.83	193.37	194.44	216.22			
備註 REMARK	***為達到此速比時，必須搭配6P馬達使用 ***IT NEED USE 6 POLE MOTOR TO REACH CERTAIN RATIO						

公稱速比 NORMAL RATIO	高段實際減速比 ACTUAL RATIO						
	0.1KW	0.2KW	0.4KW	0.75KW	1.5KW	2.2KW	3.7KW
250	258.02	267.07	250.05	244.62			
300	306.03	304.74	282.89	299.84			
350	354.98	367.70	357.57	359.81			
400	389.75	377.61	401.21	381.87			
450	468.00	435.77	468.71	458.24			
500	528.35	496.40	510.97	518.42			
600	600.78	566.42	605.37	602.14			
700	700.07	704.66	701.91	703.57			
800	825.28	805.32	810.36	814.66			
900	922.95	894.80	893.94	921.64			
1000	1008.09	1036.04	1014.40	985.00			
1100	1097.35	1118.51	1102.53	1114.35			
1200	1224.82	1172.26	1214.91	1199.37			
1300	1329.80	1291.19	1298.22				
1400	1374.44	1393.98					
1500	1517.32	1540.55	1484.89	1492.43			
1600	1582.76	1613.99	1574.88	1612.36			
1650							
1700	1711.73	1685.55	1728.08				
1800	1775.20	1838.52	1821.00	1832.99			

輕負載縮框型 LIGHT DUTY

公稱速比 NORMAL RATIO	低段實際減速比 ACTUAL RATIO						
	0.1KW	0.2KW	0.4KW	0.75KW	1.5KW	2.2KW	3.7KW
3				2.99	2.93		
5				5.14	5.03		
10				10.01	9.96		
15		15.09	15.06	15.06	15.03		15.71
20		19.90	20.14	20.14	19.49		19.37
25		26.81	26.18	26.18	25.27		23.72
30		30.06	29.31	28.93	28.93		29.25
40		40.33	44.20	43.07	41.64		41.82
50		50.59	56.38	52.64	52.05	51.97	51.96
60	60.49	60.49	56.37	57.06	57.33	59.15	59.13
70			72.67	69.75	71.66	70.23	
80			82.92	82.22	77.40	79.93	
90	89.62	89.62	92.81	88.83	86.00		
100		103.78	98.24	100.49	107.50		
120	122.49	116.20	120.07	115.15	121.67		
140	140.41	133.05	135.83	135.00	136.26		
160	161.33	162.73	155.64	150.00	163.70		
180	***183.74	182.17	174.24	***180.00	***182.50		
200	***210.62	215.87		***202.50	***204.39		
備註 REMARK	***為達到此速比時，必需搭配6P馬達使用 ***IT NEED USE 6 POLE MOTOR TO REACH CERTAIN RATIO						

公稱速比 NORMAL RATIO	高段實際減速比 ACTUAL RATIO						
	0.1KW	0.2KW	0.4KW	0.75KW	1.5KW	2.2KW	3.7KW
250	255.98	258.02	255.16	264.54			
300	300.50	291.90	300.12	299.28			
350	340.02	354.98	344.47	356.29			
400	396.18	389.75	389.76	401.72			
450		467.84	443.98	457.24			
500	510.63	528.35	493.38	519.30			
600	610.64	600.78	594.88	599.53			
700	687.84		717.74	705.75			
800	802.78	825.28	800.32	815.69			
900	908.34		884.57	922.80			
1000	1007.13	1052.10	1000.40	1016.86			
1200	1321.92	1224.82	1200.48	1210.37			
1500	1485.90	1523.73	1500.61	1484.56			
1800	1810.42	1771.61	1775.94	1775.2			

4-8 潤滑油 LUBRICANT

本公司於出廠前已添加潤滑油脂(BT-860-0)，在正常條件下運轉20,000小時可不必更換潤滑油脂，但在特殊環境條件下運轉時，如：高溫，長時間運轉，衝擊負荷等，則換油頻率為10,000-15,000小時。

ALL REDUCERS FILLED WITH LUBRICANT(BT-860-0)BEFORE DELIVERY, NORMALLY, IT NO NEED TO REPLACE LUBRICANT FOR FIRST 20,000 HRS RUNNING, BUT IF WORKING IN SPECIAL APPLICATION, SUCH AS: HIGH TEMPERATURE, 24 HRS RUNNING , HEAVY DUTY IMPACT....etc. THEN LUBRICANT NEED TO BE CHANGED IN EVERY 10,000-15,000 WORKING HOURS.

可替換潤滑油脂 (EXCHANGEABLE LUBRICANT)

廠牌 (BRAND)	SHELL	COSMD	MOBIL	昭和石油	台製
規格 (SPEC')	OMALA OIL 320	EP-320	MOBIL GEAR 632	ISO VG EP 320	國光牌 HD-320

油量表/重量表 (LUBRICANT / WEIGHT TABLE)

馬力 CAPACITY	出力軸 OUTPUT SHAFT	本體框號 HOUSING CODE	機型TYPE								
			油量表 (公升) LUBRICANT(L)		重量表 (公斤) WEIGHT(KG)						
			CH CHM CHD	CV CVM CVD	CH	CHM	CHD	CV	CVM	CVD	
100W 1/8HP	φ18	1#	0.19	0.18	5.60	5.22	2.90	5.80	5.12	2.80	
	φ22	2#	0.38	0.39	7.30	6.40	4.00	7.30	6.52	4.10	
200W 1/4HP	φ28	1#+3#	0.8	0.85	14.6	12.4	11.3	14.6	12.52	11.4	
	φ18	1#	0.17	0.18	7.00	5.22	2.90	7.00	5.12	2.80	
	φ22	2#	0.38	0.39	8.60	6.42	4.00	8.80	6.52	4.10	
400W 1/2HP	φ28	3#	0.63	0.68	11.0	9.12	8.30	10.8	8.92	8.10	
	φ32	2#+4#	1.30	1.40	27.6	24.0	23.0	28.0	24.4	22.8	
	φ22	2#	0.38	0.39	11.1	6.42	4.80	11.2	6.52	4.90	
750W 1HP	φ28	3#	0.63	0.68	14.2	9.12	8.30	14.0	8.92	8.10	
	φ32	4#	0.95	1.05	27.0	22.2	21.5	26.9	23.2	22.5	
	φ40	3#+5#	1.80	1.90	46.0	39.8	39.1	47.0	40.8	40.1	
1500W 2HP	φ28	3#	0.63	0.68	15.5	12.1	8.30	15.0	11.9	8.10	
	φ32	4#	0.95	1.05	27.6	25.1	21.5	28.0	26.1	22.5	
	φ40	5#	1.26	1.38	42.3	37.3	32.0	41.9	36.3	31.0	
	φ50	3#+6#	3.00	3.13	91.5	83.5	79.2	91.5	82.5	77.2	
2200W 3HP	φ32	4#	0.95	1.05	33.6	25.0	22.0	34.6	26.0	23.0	
	φ40	5#	T	1.470	1.590	49.6	37.3	33.0	49.0	36.3	32.0
			TT	1.260	1.470						
	φ50	6#		2.520	2.600	94.0	74.3	70.0	94.0	71.3	67.0
			3.470	3.650	105.0	--	--	106.0	--	--	
3700W 5HP	φ40	5#	D	1.680	1.800	49.8	40.8	36.5	51.0	39.8	35.5
			T	1.490	1.590						
	φ50	6#		2.520	2.600	92.5	77.8	73.5	88.5	74.8	70.5
φ40	5#		1.680	1.800	54.8	43.8	39.5	55.3	42.8	38.5	
			2.520	2.600	98.5	78.8	74.5	94.5	75.8	71.5	

備註：1. 此表僅供參考，具體以實物為準
1. THIS TABLE IS FOR REFERENCE ONLY, SUBJECT TO THE SPECIFIC KIND

4-9 速比/段數適用表 (RATIO / GEAR STAGE TABLE)

馬力 CAPACITY	速比 RATIO	雙段 (D) 2 ND STAGE	三段 (T) 3 RD STAGE	雙本體 1#+3# TWIN HOUSING	雙本體 2#+4# TWIN HOUSING	雙本體 3#+5# TWIN HOUSING	雙本體 3#+6# TWIN HOUSING
1/8HP	1/3-1/50	D					
	1/60-1/200		T				
	1/150,180,200		T				
	1/250-1/1800			DD			
1/4HP	1/3-1/35	D					
	1/40-1/200		T				
	1/160,180,200		T				
	1/250-1/1800				DD		
1/2HP	1/3-1/35	D					
	1/40-1/200		T				
	1/250-1/1800					DD	
1HP	1/3-1/30	D					
	1/40-1/120		T				
	1/125-1/200		(TT)				
	1/250-1/1800						DD
2HP	1/3-1/22	D					
	1/25-1/50		T				
	1/55-1/100						
	1/105,115,120		T				
3HP	1/110-1/180		T				
	1/3-1/15	D					
	1/20-1/100		T				
5HP	1/3-1/25	D					
	1/30-1/60		T				

**馬達到以下速比時，必需搭配6P馬達使用 TO REACH CERTAIN RATIO THAT NEED TO USE 6 POLE MOTOR

2HP 1/130,1/150,1/160,1/170,1/180

4-10 接線方式 WIRING DIAGRAM

(1) 三相馬達/剎車器接線方式 (THREE PHASE MOTOR W/BRAKE UNIT DIAGRAM)

(a) 三相六條馬達電源線 (FOR SIX WIRES)

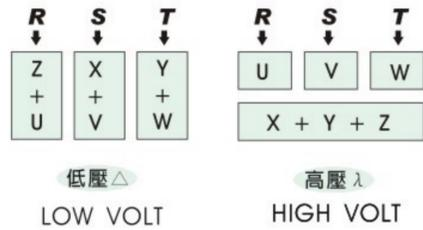

(b) 三相九條馬達電源線 (FOR NINE WIRES)

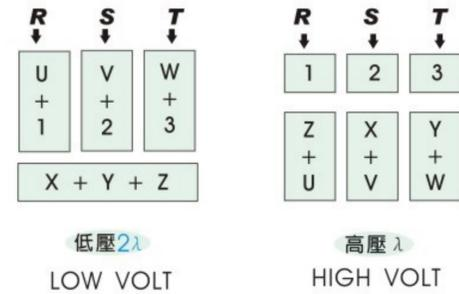

(c) 三相六條馬達電源線附交流剎車器 (SIX WIRES W / AC BRAKE UNIT)

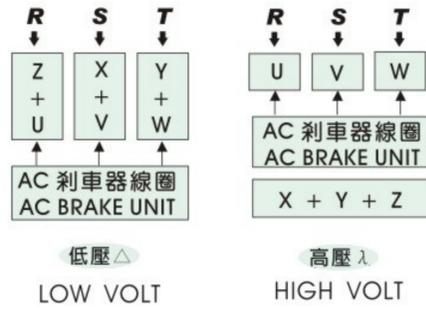

(d) 三相九條馬達電源線附交流剎車器 (NINE WIRES W / AC BRAKE UNIT)



(e) 六條馬達電源線附直流剎車器 (SIX WIRES W / DC BRAKE UNIT)

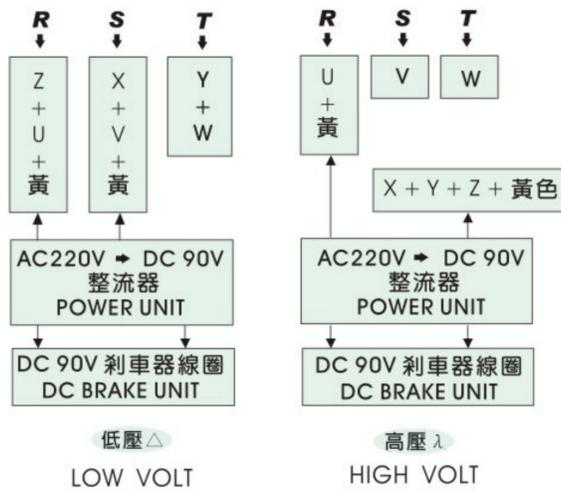

(f) 九條馬達電源線附直流剎車器 (NINE WIRES W / DC BRAKE UNIT)

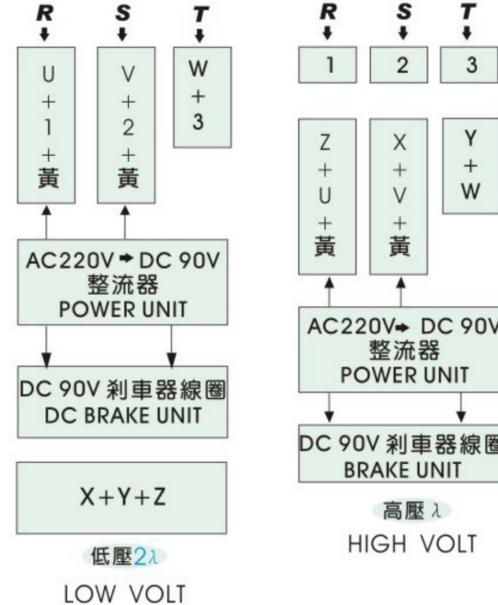

(2) 單相馬達/剎車器接線方式 (SINGLE PHASE MOTOR W / BRAKE UNIT DIAGRAM)

(a) 單相低壓 LOW VOLTAGE-110V

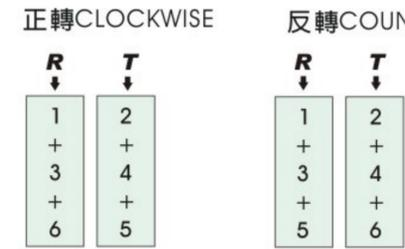

(b) 單相高壓 HIGH VOLTAGE-220V

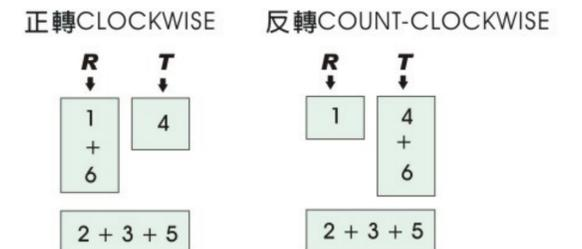

(c) 單相低壓110V附直流剎車器 LOW VOLTAGE 110V WITH DC BRAKE UNIT

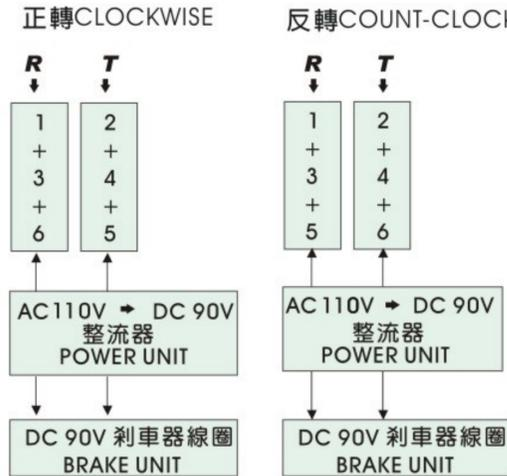

(d) 單相高壓220V附直流剎車器 HIGH VOLTAGE 220V WITH DC BRAKE UNIT

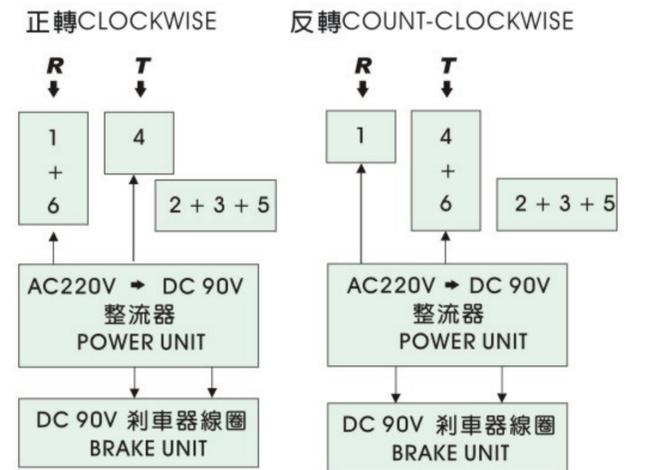

(3) 加溫控接線方式 (TEMPERATURE CONTROL WIRING)

(a) 三相馬達加溫控接線圖 3-PHASE THERMOSTAT WIRING DIAGRAM

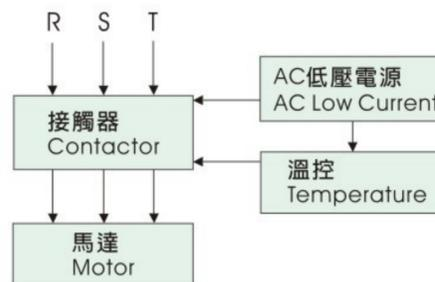

(b) 單相馬達加溫控接線圖 1-PHASE THERMOSTAT WIRING DIAGRAM

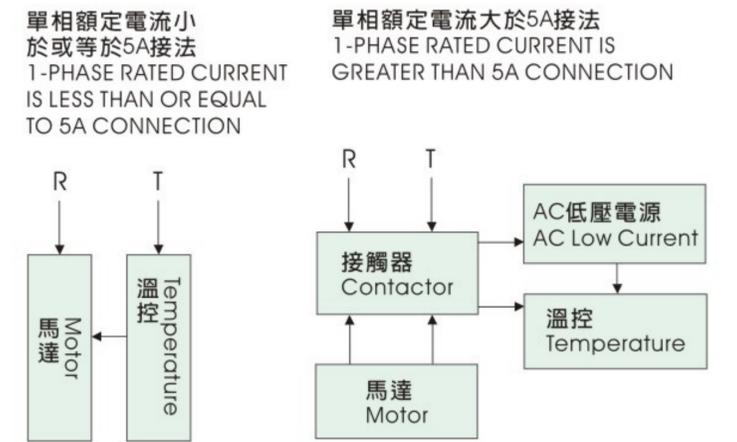

4-11 剎車器性能說明 (FUNCTION FOR BRAKE UNIT)

4-11-1 交流剎車器規格 (AC BRAKE UNIT SPECIFICATION)

輸出馬力 CAPACITY (HP)	允許最高轉速 PERMIT MAX RPM	剎車制動力 TORQUE (KG-M)	剎車間隙 CLEARANCE (MM)	來令片 BRAKE DISC		重量 WEIGHT (KG)
				外徑 O/D	內徑 I/D	
1/4HP4P	4000	0.15-0.30	0.4-1.2	83	48	1.6
1/2HP4P-1/4HP6P	4000	0.15-0.40	0.4-1.2	112	65	4.0
1HP4P-1/2HP6P	4000	0.25-0.70	0.5-1.3	130	68	4.3
2HP4P-1HP6P	3600	0.42-1.50	0.5-1.4	140	78	5.8
3HP4P-2HP6P	3600	0.92-2.00	0.5-1.4	150	78	7.0
5HP4P-3HP6P	3600	1.80-3.50	0.5-1.5	170	86	9.0
7.5HP4P-5HP6P	3600	2.80-5.50	0.5-1.7	170	86	12.5
10HP4P-7.5HP6P	3400	4.00-7.00	0.6-1.7	190	105	15.0
15HP4P-10HP6P	3400	6.00-11.00	0.6-1.7	200	110	23.6
20HP4P-15HP6P	3200	8.00-13.00	0.6-1.8	240	125	31.5
25HP4P-20HP6P	2600	15.00-23.00	0.8-2.0	300	145	54.5
30HP4P-25HP6P	2600	15.00-23.00	0.8-2.0	300	145	54.5
40HP4P-30HP6P	2600	15.00-23.00	0.8-2.0	300	145	54.5

備註
REMARK

- AC剎車器安裝尺寸較長於原有標準馬達。
AC BRAKE UNIT LENGTH LONGER THAN ORIGINAL STANDARD MOTOR.
- 適用電壓AVAILABLE VOLTAGE
220V,380V,400V,415V,440V,460V.
- 可接受特殊訂製AC剎車器及專用剎車機型
AVAILABLE FOR SPECIAL BRAKE DESIGN
- BA07-BA40為複板式剎車器
DOUBLE BRAKE DISC SYSTEM FOR 7.5HP4P-40HP4P

4-11-2 直流安全式剎車器規格 (DC BRAKE UNIT SPECIFICATION)

輸出馬力 CAPACITY (HP)	剎車制動力 TORQUE (KG-M)	剎車間隙 CLEAR- ANCE (MM)	剎車時間 BRAKE (SEC)	釋放時間 RELEASE (SEC)	剎車線圈BRAKE COIL			重量 WEIGHT (KG)
					電壓 VOLTAGE (DC-V)	電流 AMP (A)	阻抗OHM (Ω)	
1/4HP4P	0.20	0.2-0.60	0.22	0.12	95±10%	0.17	565	3.5
1/2HP4P	0.40	0.2-0.60	0.24	0.13	95±10%	0.28	336	4.0
1HP4P	0.80	0.3-0.65	0.22	0.12	95±10%	0.41	233	5.0
2HP4P	1.50	0.3-0.65	0.28	0.15	95±10%	0.57	167	6.0
3HP4P	2.20	0.4-0.70	0.28	0.18	95±10%	0.73	130	8.0
5HP4P	4.50	0.4-0.70	0.28	0.18	95±10%	0.73	130	10.0
7.5HP4P	5.60	0.5-0.90	0.38	0.21	95±10%	1.02	93	12.5

備註
REMARK

- 直流剎車器安裝尺寸相同於原有標準馬達。
DC BRAKE UNIT LENGTH SAME AS ORIGINAL STANDARD MOTOR.
- 採用非石棉剎車來令片材質
ADOPT MATERIAL WITH NON-ASBESTOS BRAKE DISC.
- 適用電壓AVAILABLE VOLTAGE
220V,380V,400V,415V,440V,460V.
- 剎車電壓為 DC90V.BRAKE COIL VOLTAGE:DC90V.
- 選用配件OPTIONAL DESIGN
a.可附加手動釋放剎車裝置
AVAILABLE FOR MANUAL RELEASE BRAKE SYSTEM. b.可接受特殊訂製DC剎車器及專用剎車機型
AVAILABLE FOR SPECIAL BRAKE DESIGN

4-12 標準東元/大同鑄鐵馬達 IEC CAST IRON MOTOR

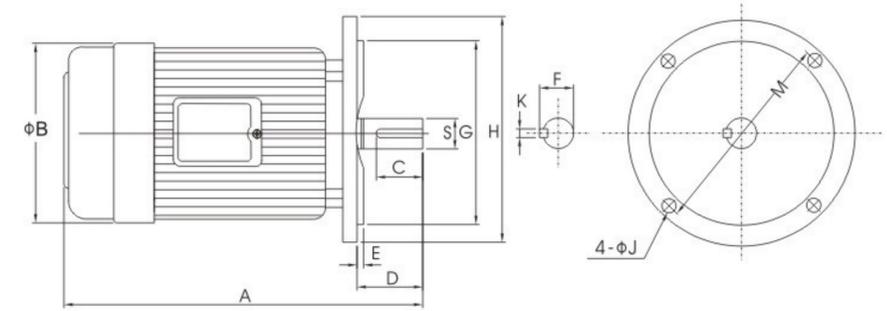

IEC標準三相立式馬達尺寸表 (IEC 3-PHASE MOTOR)

輸出馬力 CAPACITY			框號 FRAME	A	B	C	D	E	F	G	H	J	K	M	S	重量 WEIGHT
2P	4P	6P														
1/4	1/4	--	63	248	144	10	23	3.5	12.5	110	160	10	4	130	11	8 KG
1/2	1/2	1/4	71	278	162	14	30	3.5	16	110	160	10	5	130	14	12 KG
1	1	1/2	80	282	177	25	40	3.5	21.5	130	200	12	6	165	19	16 KG
2,3	2	1	90L	272	200	32	50	3.5	27	130	200	12	8	165	24	25 KG
--	3	2	100L	375	219	40	60	4.0	31	180	250	14.5	8	215	28	32 KG
5	5	3	112M	431	235	40	60	4.0	31	180	250	14.5	8	215	28	43 KG
7.5	7.5	5	132S	454	273	56	80	4.0	41	230	300	14.5	10	265	38	67 KG
--	10	7.5	132M	492	273	56	80	4.0	41	230	300	14.5	10	265	38	74 KG

【生活箴言】

生活大師

你不能決定生命的長度，但你可以決定生命的寬度。

你不能左右天氣，但你可以改變心情。

你不能改變容貌，但你可以展現笑容。

你不能控制他人，但你可以掌握自己。

你不能預知明天，但你可以利用今天。

你不能樣樣順利，但你可以事事盡力。

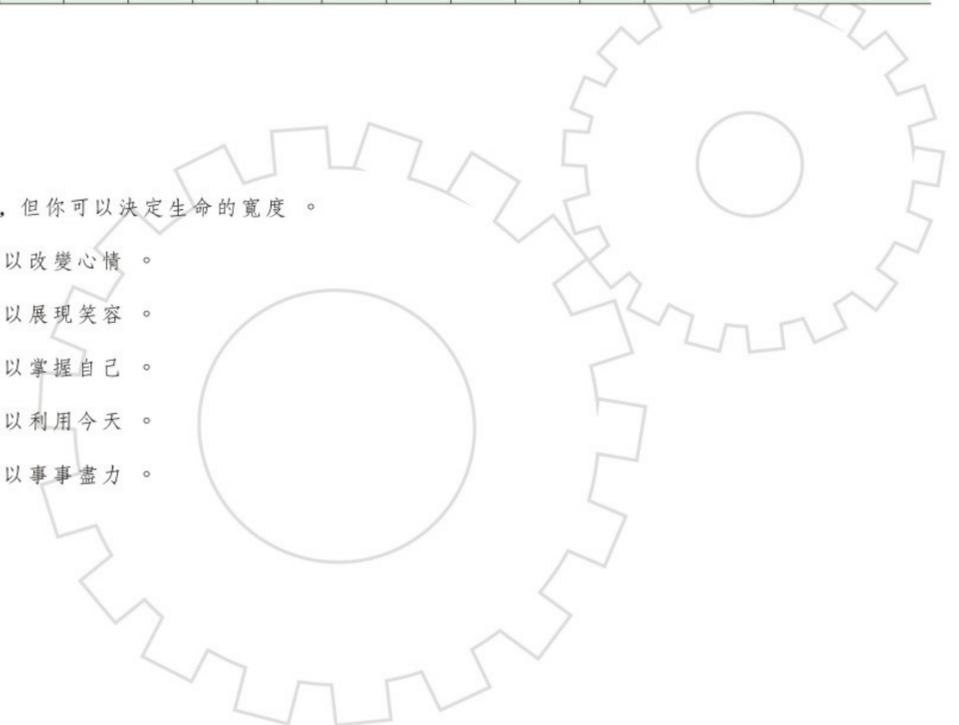

4-13 鍵/鍵槽加工尺寸 (KEY / KEYWAY DIMENSION)

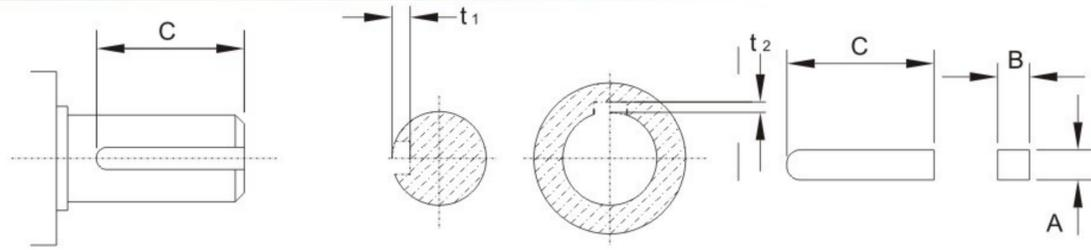

軸徑 SHAFT DIA	鍵 KEY		鍵槽 KEYWAY			
	新JIS規範 NEW JIS SPEC'	舊JIS規範 OLD JIS SPEC'	新JIS規範 NEW JIS SPEC' (SHAFT / HOLE)		舊JIS規範 OLD JIS SPEC' (SHAFT / HOLE)	
S	A x B x C	A x B x C	t1	t2	t1	t2
φ 11.0	4 x 4 x C	4 x 4 x C	2.5 ⁺⁰ / _{+0.1}	1.8 ⁺⁰ / _{+0.1}	2.5 ⁺⁰ / _{+0.1}	2.0 ⁺⁰ / _{+0.1}
φ 14.0	5 x 5 x C	5 x 5 x C	3.0 ⁺⁰ / _{+0.1}	2.3 ⁺⁰ / _{+0.1}	3.0 ⁺⁰ / _{+0.1}	2.5 ⁺⁰ / _{+0.1}
φ 18.0	6 x 6 x C	6 x 6 x C	3.5 ⁺⁰ / _{+0.1}	2.8 ⁺⁰ / _{+0.1}	3.5 ⁺⁰ / _{+0.1}	3.0 ⁺⁰ / _{+0.1}
φ 19.0	6 x 6 x C	6 x 6 x C	3.5 ⁺⁰ / _{+0.1}	2.8 ⁺⁰ / _{+0.1}	3.5 ⁺⁰ / _{+0.1}	3.0 ⁺⁰ / _{+0.1}
φ 22.0	8 x 7 x C	7 x 7 x C	4.0 ⁺⁰ / _{+0.1}	3.3 ⁺⁰ / _{+0.1}	4.0 ⁺⁰ / _{+0.1}	3.5 ⁺⁰ / _{+0.1}
φ 24.0	8 x 7 x C	8 x 7 x C	4.0 ⁺⁰ / _{+0.2}	3.3 ⁺⁰ / _{+0.2}	4.0 ⁺⁰ / _{+0.2}	3.5 ⁺⁰ / _{+0.2}
φ 28.0	8 x 7 x C	8 x 7 x C	4.0 ⁺⁰ / _{+0.2}	3.3 ⁺⁰ / _{+0.2}	4.0 ⁺⁰ / _{+0.2}	3.5 ⁺⁰ / _{+0.2}
φ 32.0	10 x 8 x C	10 x 8 x C	5.0 ⁺⁰ / _{+0.2}	3.3 ⁺⁰ / _{+0.2}	4.5 ⁺⁰ / _{+0.2}	4.0 ⁺⁰ / _{+0.2}
φ 40.0	12 x 8 x C	12 x 8 x C	5.0 ⁺⁰ / _{+0.2}	3.3 ⁺⁰ / _{+0.2}	4.5 ⁺⁰ / _{+0.2}	4.0 ⁺⁰ / _{+0.2}
φ 45.0	14 x 9 x C	12 x 8 x C	5.5 ⁺⁰ / _{+0.2}	3.8 ⁺⁰ / _{+0.2}	4.5 ⁺⁰ / _{+0.2}	4.0 ⁺⁰ / _{+0.2}
φ 50.0	14 x 9 x C	15 x 10 x C	5.5 ⁺⁰ / _{+0.2}	3.8 ⁺⁰ / _{+0.2}	5.0 ⁺⁰ / _{+0.2}	5.5 ⁺⁰ / _{+0.2}
φ 55.0	16 x 10 x C	15 x 10 x C	6.0 ⁺⁰ / _{+0.2}	4.3 ⁺⁰ / _{+0.2}	5.0 ⁺⁰ / _{+0.2}	5.5 ⁺⁰ / _{+0.2}
φ 65.0	18 x 11 x C	18 x 12 x C	7.0 ⁺⁰ / _{+0.2}	4.4 ⁺⁰ / _{+0.2}	6.0 ⁺⁰ / _{+0.2}	6.5 ⁺⁰ / _{+0.2}
φ 75.0	20 x 12 x C	20 x 13 x C	7.5 ⁺⁰ / _{+0.2}	4.9 ⁺⁰ / _{+0.2}	7.0 ⁺⁰ / _{+0.2}	6.5 ⁺⁰ / _{+0.2}
φ 90.0	25 x 14 x C	24 x 16 x C	9.0 ⁺⁰ / _{+0.2}	5.4 ⁺⁰ / _{+0.2}	8.0 ⁺⁰ / _{+0.2}	8.5 ⁺⁰ / _{+0.2}
φ 100.0	28 x 16 x C	28 x 18 x C	10.0 ⁺⁰ / _{+0.2}	6.4 ⁺⁰ / _{+0.2}	9.0 ⁺⁰ / _{+0.2}	10.0 ⁺⁰ / _{+0.2}
φ 115.0	28 x 16 x C	28 x 18 x C	10.0 ⁺⁰ / _{+0.2}	6.4 ⁺⁰ / _{+0.2}	9.0 ⁺⁰ / _{+0.2}	10.0 ⁺⁰ / _{+0.2}

4-14 相關計算 CALCULATE DATA

(A) 連結係數表 (CONNECTION FACTOR)

鏈輪 SPROCKET	1.00
齒輪 GEAR	1.25
三角皮帶 BELT	1.50
平皮帶 FLAT BELT	2.50

(B) 荷重係數表 (SERVICE FACTOR)

減速機負載等級 LOAD GRADE	每日運轉時間 (HRS) DAILY OPERATING HOURS			
	1-2	3-8	9-15	16-24
均一負載 UNIFORM LOAD	0.80	0.90	1.20	1.30
中級衝擊負載 MEDIUM IMPACT LOAD	1.00	1.20	1.30	1.50
重級衝擊負載 HEAVY IMPACT LOAD	1.20	1.50	1.75	2.00

(C) 符號說明 (CODE DETAILS)

V=速度 SPEED (M/MIN)	E=效率 EFFICIENCY(%)	1 INCH = 2.54 CM
I=減速比 RATIO	N ₂ =出力軸轉速(RPM) OUTPUT SHAFT SPEED	1 FOOT = 12 INCH
T=輸出扭力 (KG-M) OUTPUT TORQUE	D=滾輪直徑 (MM) ROLLER DIAMETER	1 KW = 1000W 1 KW = 1.34 HP
K=連結係數 CONNECTING FACTOR	R=滾輪半徑 (MM) ROLLER RADIUS	1 KG-M = 7.233 FT-LB 1 KG-M = 86.8 IN-LB
F=荷重係數 SERVICE FACTOR	KW1(HP1)=入力馬力 INPUT CAPACITY	1 KG = 2.2 LB 1 LB = 0.4536 KG
W=荷重 (KG) LOAD	KW2(HP2)=輸出馬力 OUTPUT CAPACITY	N ₁ = 入力迴轉速 (r/min) INPUT SHAFT ROTATION SPEED

(D) 基本傳動公式 (BASIC FORMULAR)

減速比 RATIO	$I = N_2 / N_1$
迴轉速度 ROTATION SPEED (r / min)	$N_1 = V / \pi D$
輸出扭矩 OUTPUT TORQUE (KG-M)	$T = W \times R \times K$
輸入馬力 INPUT HORSEPOWER (公制 KW)	$KW1 = N_1 \times T / 974$
輸入馬力 INPUT HORSEPOWER (英制 HP)	$HP1 = N_1 \times T / 727$
輸出馬力 OUTPUT HORSEPOWER (公制 KW)	$KW2 = KW1 \times F / E$
輸出馬力 OUTPUT HORSEPOWER (英制 HP)	$HP2 = HP1 \times F / E$

(E) 減速機水平輸送場合符號說明及傳動公式 (DESCRIPTION AND TRANSMISSION)

輸送速度 (r/min) TRANSMISSION SPEED	V	輸送帶摩擦係數 BELT FRICTION COEFFICIENT	μ
滾輪直徑 (MM) ROLLER DIAMETER	D	鏈輪傳動效率 (%) Chain drive efficiency	η_1
載重量 (KG) LOAD	W	減速機傳動效率 (%) REDUCER TRANSMISSION EFFICIENCY	$\eta_2 = 0.9$
出力軸主動鏈輪齒數 OUTPUT SHAFT TEETH	t1	輸送機被動鏈輪齒數 CONVEYOR PASSIVE SPROCKET TEETH	t2
輸送帶所需扭力 (KG-M) BELT TORQUE	T1	減速機減速比 REDUCER RATIO	I
減速機扭力 (KG-M) REDUCER TORQUE	T2	減速機出力軸迴轉速 (r/min) REDUCER OUTPUT SHAFT ROTATION SPEED	N2
荷重係數 SERVICE FACTOR	F (查 4-13 表(B)) F (FIND 4-13 TABLE(B))		

輸送機迴轉速 (r/min) TRANSMISSION SPEED	$N1 = V / \pi D$
減速機出力軸迴轉速 (r/min) REDUCER OUTPUT SHAFT ROTATION SPEED	$N2 = N1 \times (t2 / t1)$
減速機減速比 (I) REDUCER RATIO	50hz $I = 1500 / N2$ 60hz $I = 1800 / N2$
輸送帶所需扭力 (KG-M) BELT TORQUE	$T1 = W \times D / 2 \times \mu / \eta_1$
減速機所需扭力 (KG-M) REDUCER TORQUE	$T2 = T1 \times (t1 / t2) / \eta_2$
考慮荷重係數減速馬達扭力 GEAR MOTOR TORQUE (SERVICE FACTOR BE CONSIDER)	$T3 = T2 \times F$
馬力 (HP) CAPACITY	$HP = T3 \times N2 / 746$

Troubleshooting 故障排除

直流剎車器故障排除 TROUBLESHOOTING FOR DC BRAKE UNIT

不良原因 DEFECTIVE REASON	原因分析 POSSIBLE ANALYSIS	解決方式 SOLUTION
剎車器不動作 NO ACTION	未供電源 NO POWER INSIDE BRAKE	供應電源SUPPLY POWER
	來令片磨損 BRAKE DISC WORN OUT	換新來令片 USE NEW BRAKE DISC
	間隙過大LARGE CLEARANCE	調整間隙ADJUST CLEARANCE
	電源電壓不足LOW VOLTAGE	提供正確電壓 USE CORRECT VOLTAGE
	電源供應器損壞 POWER SUPPLY DAMAGE	電源供應器換新 USE NEW POWER SUPPLY
	異物入侵DIRTY INSIDE	清潔零件CLEAN PARTS
	使用電壓錯誤 WRONG VOLTAGE	使用正確電壓 CORRECT VOLTAGE
	接線脫落 CONNECT WIRE LOST	重新接線 RE-CONNECT WIRE
	來令片卡死 BRAKE DISC LOCKED	清潔零件CLEAN PARTS
	剎車線圈燒毀 BRAKE COIL BURNED-OUT	剎車線圈換新 USE NEW BRAKE COIL
剎車移動 OVER STOP	來令片磨損 BRAKE DISC WORN OUT	換新來令片 USE NEW BRAKE DISC
	間隙過大LARGE CLEARANCE	調整間隙ADJUST CLEARANCE
	來令片沾染油漬 SURFACE W/OIL	清潔來令片 CLEAN BRAKE DISC
	負載過大OVER LOADING	重新設計 RE-DESIGN BRAKE UNIT
	剎車表面歪斜 DISC SURFACE TWIST	更換零件USE NEW PARTS
	下降衝量過大 HUGE MOMENTUM	機構重新設計 SYSTEM RE-DESIGN
	選用機型錯誤 SELECT WRONG TYPE	選用正確機型RE-SELECT UNIT
	環境溫度過高 HIGH TEMPERATURE	檢討環境溫度 ADJUST TEMPERATURE

減速機故障排除 TROUBLESHOOTING FOR GEAR MOTOR

不良原因 DEFECTIVE REASON	原因分析 POSSIBLE ANALYSIS	解決方式 SOLUTION	
噪音 NOISE	齒輪敲擊聲 KNOCKING	齒輪表面受傷 HURT GEAR SURFACE	更換受傷齒輪組 REPLACE GEAR SET
	連續性雜音 CONTINUALLY	培林損壞 BAD BEARING	更換損壞培林 REPLACE BEARING
	週期性雜音 PERIODICALLY	異物附著齒面 PARTICLE INSIDE	檢查齒輪齒面 CHECK GEAR
	嘶嘶聲 NEIGH	油量不足 LACK OF LUBRICANT	添加潤滑油 FILL WITH LUB-OIL
	斷續性雜音 INTERMITTENTLY	潤滑油不潔 DIRTY LUBRICANT	更換新潤滑油 REPLACE LUBRICANT
振動 VIBRATING	固定底座振動 MOUNTING BASE MOVEMENT	安裝平面歪斜 BAD SURFACE MOUNTING	重新調整固定底座 RE-ADJUST MOUNTING BASE
	出力軸振動 OUTPUT SHAFT MOVING	培林損壞 BEARING BROKEN	更換損壞培林 REPLACE WOUNDED BEARING
	內部齒輪零件振動 INSIDE GEAR PARTS MOVEMENT	齒輪受傷 GEAR WOUNDED	更換受傷齒輪 REPLACE WOUNDED GEAR
	本體振動 HOUSING VIBRATING	齒輪組安裝不良 BAD GEAR ASSEMBLY	重新調整齒輪組 RE-ADJUST GEAR SET
漏油 LEAKAGE	油封漏油 OIL SEAL LEAKAGE	油封硬化 OIL SEAL TOO HARDEN	更換損壞油封 REPLACE WOUNDED OIL SEAL
	本體漏油 HOUSING LEAKAGE	本體有砂孔 HOUSING HAD SAND HOLE	更換砂孔本體 REPLACE SAND HOLE HOUSING
	結合面漏油 CONNECT SURFACE LEAKAGE	O-型環損壞 O-RING BROKEN	更換損壞O-型環 REPLACE WOUNDED O-RING
過熱 OVER-HEATING	油封 BAD OIL SEAL	油封太緊 OIL SEAL TOO TIGHT	更換太緊油封 REPLACE TIGHTEN OIL SEAL
	本體過熱 HOUSING TOO HEAT	過負載 OVER LOAD RUNNING	重新計算負載馬力 RE-CALCULATE LOADING
	缺潤滑油 LESS LUBRICANT	油量不足 LACK OF LUBRICANT	加入潤滑油 FILL WITH LUBRICANT
	馬達過熱 MOTOR TOO HEAT	馬達不良 DEFECTIVE MOTOR	更換新馬達 REPLACE NEW MOTOR

Countries voltage

各國電壓表

國名 COUNTRY	頻率 (HZ)	單相 1-PHASE	三相 3-PHASE	國名 COUNTRY	頻率 (HZ)	單相 1-PHASE	三相 3-PHASE
阿根廷 Argentina	50	220	220/380	日本 Japan	50/60	100/200	200
澳洲 Australia	50	240	240/415	科威特 Kuwait	50	100/200	200
奧地利 Austria	50	220	220/380	黎巴嫩 Lebanon	50	110/220	220/380
孟加拉 Bangladesh	50	230	230/400	馬來西亞 Malaysia	50	115/240	240/415 400/440
比利時 Belgium	50	127/220	220/380	荷蘭 Netherlands	50	110/220	220/230
巴西 Brazil	50 60	110/220 127	220/380	紐西蘭 New Zealand	50	230	230/400
緬甸 Burma	50	230	230/440	巴基斯坦 Pakistan	50	230	220/380 230/400
高棉 Cambodia	50	120	220/380	沙烏地阿拉伯 Saudi-arabia	50 60	127/220	220/380 230/400
智利 Chile	50	220	220/380	敘利亞 Syria	50	115/200	220/380
中國 China	50	220	220/380	新加坡 Singapore	50	115/230	230/400
捷克 Czechoslovakia	50	120/220	220/380	南非 South-africa	50	220/230	220/380 230/400
丹麥 Denmark	50	220	220/380	西班牙 Spain	50	127/220	220/380
埃及 Egypt	50	220	220/380	瑞士 Switzerland	50	220	220/380
芬蘭 Finland	50	220	220/380	泰國 Thailand	50	110/220	220/380
法國 France	50	115/127/ 220	220/380	土耳其 Turkey	50	127/220/230	220/380
德國 Germany	50	110/220	220/380	英國 U. K.	50	240	240/415
希臘 Greece	50	220	220/380	越南 Viet-Num	50	127/220	220/380
香港 Hong kong	50	110/200/ 230	220/380	加拿大 Canada	60	110/120	220/240/480
匈牙利 Hungary	50	220	220/380	哥倫比亞 Colombia	60	110/220	220/380
冰島 Iceland	50	220	220/380	古巴 Cuba	60	115/120	240
印度 India	50	230	220/380 230/400	厄瓜多爾 Ecuador	60	120/127	208/220
印尼 Indonesia	50	127/200	220/380	韓國 Korea	60	100/200	200
伊拉克 Iraq	50	220	220/380	秘魯 Peru	60	110/220	220
以色列 Israel	50	230	230/400	菲律賓 Philippines	60	110/220	220/440
意大利 Italy	50	127/220	220/380	美國 U.S.A.	60	120/240	240/480

1. 本公司有改良設計變更內容的權利 .
SPECIFICATIONS MODIFIED WITHOUT NOTICE
2. 非經本公司同意，不得轉載目錄圖文內容 .
NOT ALLOW FOR PUBLISH WITHOUT FORMAL APPROVED .